

**TENDER DOCUMENT FOR  
CONSTRUCTION OF BOUNDARY  
WALL AND RCC RETAINING WALL AT  
PLOT NO. 24/7, INDIRA NAGAR,  
LUCKNOW**

## INDEX

Volume-I	
1. Notice inviting tender	
2. General Instructions to Contractors and Special Conditions	
3. Safety Code	
4. Conditions of Contract	
5. Appendix	
6. Additional Conditions	
7. Specifications	
8. Articles of Agreement (Annexure-I)	
9. Bank guarantee format	
10. Schedule of quantity (volume-II)	
11. Drawings	

**GENERAL INSTRUCTIONS TO  
CONTRACTORS AND SPECIAL CONDITIONS**

1.	Tender submission and Place	GIC & SC	13
2.	Tender receiving time	GIC & SC	13
3.	Tender format, opening time and forfeiture of EMD	GIC & SC	13
4.	Reserving right for non-acceptance of lowest bidder		14
5.	Form of EMD	GIC & SC	14
6.	EMD, ISD, RMD, SD & Compensation from SD	GIC & SC	15
7.	Signing of agreement and accredited representative	GIC & SC	16
8.	Subletting of contract and execution of sanitary works	GIC & SC	16
9.	Specifications	GIC & SC	16
10.	Contractors responsibility for instructions and approval of samples	GIC & SC	16
11.	Changes if in schedule of quantities	GIC & SC	17
12.	Bidder to obtain all information for execution of the contract	GIC & SC	17
13.	Rates quoted to include all and firm and also price variation adjustment clause	GIC & SC	17
14.	Rates to be self supporting	GIC & SC	17
15.	Time for execution of contract	GIC & SC	18
16.	Tenders only from bonafide contractors	GIC & SC	18
17.	Municipal and drainage fees	GIC & SC	18
18.	Specification should be latest version	GIC & SC	19
19.	Programme of work	GIC & SC	19
20.	Tenderer to inform himself fully	GIC & SC	19

21.	Errors, omission and description	GIC & SC	19
22.	Compliance of Safety Code	GIC & SC	21

## CONDITIONS OF CONTRACT

1.	Interpretation	CC	22
2.	Scope of Contract	CC	24
3.	Contractor to provide everything necessary at his cost		25
4.	Authorities, Notices, Patents and Royalties	CC	26
5.	Setting out of works	CC	26
6.	Materials and Workmanship to conform to description	CC	26
7.	Contractor's superintendent and representatives on the works	CC	26
8.	Dismissal of workman	CC	27
9.	Access to Works	CC	27
10.	Assignment and subletting	CC	27
11.	Alterations, additions, omissions etc.	CC	27
12.	Schedule of Quantities	CC	28
13.	Sufficiency of Schedule of Quantities	CC	28
14.	Opening up works	CC	28
15.	Prices for extras etc. ascertainment of	CC	29
16.	Removal of improper work	CC	30
17.	Defects after virtual completion	CC	30
18.	Information to be supplied/obtaining of permission by the Contractor	CC	31
19.	Information to employer regarding treasure, minerals, antiquity etc.	CC	31
20.	Insurance in respect of damages to persons and property	CC	31
21.	Date of commencement and completion	CC	34
22.	Damages for non-completion	CC	35
23.	Delay and extension of time	CC	35
24.	Failure by Contractor to comply with Bank's	CC	36

	instruction		
25.	Termination of contract by the Employer	CC	37
26.	Certificate of payments	CC	39
27.	Matter to be finally determined by Banks	CC	41
28.	Settlement of dispute by Arbitration	CC	41
29.	Right of Technical Scrutiny of Bill/Inspection	CC	42
30.	Employer entitled to recover compensation paid to workman	CC	43
31.	Abandonment of works	CC	43
32.	Return of surplus materials	CC	43
33.	Preparation of building for occupation and use on completion	CC	43
34.	Marginal notes	CC	44
35.	Address for service	CC	44

## NOTICE INVITING TENDERS

To,

Dear Sirs,

**SUB: Tender for construction of RCC Retaining Wall & Boundary Wall  
at Plot No. 24/7, Indira Nagar, Lucknow**

1. Tenders are invited from the eligible interested firms fulfilling the following criteria. The firm/ contractor should be in the business for more than seven years having proper supporting staff and infrastructure facilities.

The firm/contractor should have the following conditions:

- a) Average annual financial turnover during the last 3 years ending 31<sup>st</sup> march of the previous financial year, should be atleast 30% of the estimated cost.
- b) Experience of having successfully completed similar works during last 7 years ending last day of month previous to the tone in which applications are invited should be either of the following.
  - i) Three similar completed works costing not less than the amount equal to 40% of the estimated cost.  
  
Or
  - ii) Two similar completed works costing not less than the amount equal to 50% of the estimated cost.  
  
Or
  - iii) One similar completed work costing not less than the amount equal to 80% of the estimated cost.
- c) Similar works means large compound walls and RCC retaining walls for embankment purpose and/ other RCC structural works etc.

2. Tender forms will be available from the Premises Department, National Bank for Agriculture and Rural Development, 11, Vipin Khand, Gomti Nagar, Lucknow-226 010 (Telephone : 0522-2399168, 2399177) from 22.08.2008 to 08.09.2008 on

payment of Rs. 500 ( Rs. Five hundred only) towards cost of tender document by Demand Draft drawn on any Nationalised/ Scheduled Bank payable at Lucknow drawn in favour of National Bank for Agriculture and Rural Development.

3. The tender documents can also be downloaded from the NABARD website [www.nabard.org](http://www.nabard.org) up to **(last date)**. Those who download the tender documents from the website will be required to submit a DD of Rs. 500 towards the cost of the tender document. The sum of Rs. 500/- towards cost of tender document is non refundable. No other form of payment will be accepted.

4. The sealed tender in the prescribed Tender Form **in two separate envelopes** should be submitted, by putting the two in large envelope, superscribed ``Tender for construction of RCC retaining wall & boundary wall at plot no. 24/7, Indira Nagar, Lucknow`` to the Shri Sukhbir Singh, Chief General Manager, National Bank for Agriculture and Rural Development, UP Regional Office, 11, Vipin Khand, Gomti Nagar, Lucknow 226010 and each envelope shall also be superscribed as **Envelope no.1 and Envelope no.2** respectively alongwith **“Tender for construction of RCC retaining wall & boundary wall at plot no. 24/7, Indira Nagar, Lucknow**

**Envelope No.1** shall contain sum of Rs. 500/- (in the form of DD) **towards cost of tender document** (if downloaded from website) and Earnest Money Deposit, of Rs., 34000.00 (Rs. thirty four thousand only) in the form of Demand Draft drawn on any nationalised/ scheduled bank payable at Lucknow drawn in favour of National Bank for Agriculture and Rural Development or in the form of a Bank Guarantee, as per the format given in the tender document, from any nationalised/ scheduled bank alongwith duly filled & signed complete in all respects (Volume-I) Tender document, form of tender, All submittals as per undernoted clauses:

- i) The bidder’s proposal for supervising the work.
- ii) PAN number of the firm/contractor and experience certificate etc. meeting minimum criteria as mentioned above. The tender submitted **without** EMD are liable to be rejected.

**(Copies of satisfactory completion certificates indicating value of work and period of work may be enclosed).**

5. **Envelope No.2** shall contain Volume -II of the tender booklet containing BOQ or price bids (in duplicate) duly filled and signed complete in all respects. (Any conditions mentioned in envelope-2 shall not be taken in to consideration for evaluation of the tender). No commercial or technical condition or qualification of any sort shall be indicated by the bidder in the Envelope No.2 otherwise the tender shall be liable to be rejected.

Tender received late on account of any reason whatsoever and telegraphic tenders will not be entertained.

No other conditions shall be accepted and the bidder shall give a declaration accepting all the conditions given in the tender.

The tender shall be valid for a period of 90 days from the last date of submission of the tender.

The National Bank shall not be bound to accept the lowest tender and reserves the right to reject any or all the tenders without assigning any reason thereof.

Please note that this letter shall be supplemental to the conditions in the tender and not in derogation thereof except to the extent specifically provided herein.

6. Both the envelopes duly sealed shall be submitted to - Shri Sukhbir Singh, Chief General Manager, National Bank for Agriculture and Rural Development, UP Regional Office, 11, Vipin Khand, Gomti Nagar, Lucknow 226010, **not later than 15.00 hrs on 08.09.2008** duly superscribed as “**Tender for construction of RCC retaining wall & boundary wall at plot no. 24/7, Indira Nagar, Lucknow.**”

7. Envelope No.1 will be opened on 08.09.2008 at 15.30 hrs. on the same day at the above address in the presence of the tenderers or their authorised representatives who choose to be present.

8. **Envelope No.2 shall be opened only in respect of those tenderers who have complied with the requirements as laid down in the NIT in the Envelope No.1. Opening of envelope No.2 shall be done at a later date which shall be intimated after scrutiny of the documentary evidence submitted by the tenderers.**

9. After opening of the Envelope No.1 and assessing the Conditions and verifying the eligibility of the tenderers, the Employer will inform the eligible tenderers regarding any modifications in the tender conditions. Bidders who agreed to the changed conditions alongwith the original in TOTO will be allowed to make modifications if they so wish, in their tender prices by means of a letter to be submitted in sealed cover which alongwith their price bid, will form the final price bid. The tender will be rejected if any tenderer proposes any deviation from the above in this letter.

10. The tenderer will have to quote for all the sections included in the tender documents.

11. NABARD reserves the right to accept or reject any tender either in whole or in part without assigning any reason for doing so and do not bound themselves to accept the lowest or any other tender.

12. **The tenderers may please note that** NABARD also reserves the right to divide and distribute the work to more than one contractor. In such cases the decision will be solely at the discretion of NABARD including that of assignment of works. You are advised to ensure strict observance of commercial aspect of this tender and also of the following points:

13. Time of completion - **04 months** reconed from the 10th day of issue of work order.

14. The onus of cooperation with other contractors for any discipline in services lies on the tenderer.

15. It may please be noted that all documents that comprise the tender documents should be signed and sealed by the tenderer.

16. The successful tenderer will enter into an agreement with NABARD as per the standard format within 14 days (Annexure-1) on receipt of Letter of Acceptance of tender from NABARD.

17. This Notice Inviting Tender (NIT) shall also form part of the Tender Document.

18. Tender document shall be submitted in duplicate (one original and a photocopy).

Thanking you,

Yours faithfully,

**( Sukhbir Singh )**  
**Chief General Manager**

## FORM OF TENDER

Place :

Date :

Shri  
Chief General Manager  
National Bank for Agriculture and Rural Development  
11, Vipin Khand, Gomti Nagar,  
Lucknow

Dear Sir,

Having examined the conditions of contract, drawing, specifications, designs and schedule of quantities relating to the works specified in the memorandum hereinafter set out and having examined the site of the works specified in the said memorandum and having acquired the requisite information relating thereto as affecting the tender, I/We hereby offer to execute the works specified in the said memorandum within the time specified in the said memorandum at the rates mentioned in the attached schedule of quantities and in accordance in all respects with the specifications, designs, drawings and instructions in writing referred to in conditions of tender, the Articles of Agreement, Special Conditions, Schedule or Quantities and Conditions of Contract and with such materials as are provided for, by and in all other respects in accordance with such conditions so far as they may be applicable.

### MEMORANDUM

- (a) Description of works : Construction of construction of RCC retaining wall & boundary wall at plot no. 24/7, Indira Nagar, Lucknow
- (b) Estimated cost : Rs. 17 lakhs
- (c) Earnest money : Rs. 34000.00 in the form of DD or a bank guarantee
- Percentage, if any, to be deducted from bill (RMD) : 3% from running-account bills
- (d) Security Deposit : 5% (RMD + EMD)  
(5% of the estimated cost put to tender)

(e) Time allowed for completion : 4 months  
of the works from tenth day after  
the date of written order to  
commence work. The time will  
include monsoon months also

2. Should this tender be accepted, I/We hereby agree to abide by and fulfill the terms and provisions of the said Conditions of Contract annexed hereto so far as they may be applicable or in default thereof to forfeit and pay to the National Bank for Agriculture and Rural Development the amount mentioned in the said conditions.

3. I/We have deposited a sum of Rs. 34000.00 as Earnest money with NABARD, in the form of Demand Draft/bank guarantee issued by a Scheduled Bank, which amount is not to bear any interest. Should I/We fail to execute the contract when called upon to do so. I/We do hereby agree that this sum shall be forfeited/ invoked by me/us to the NABARD.

4. The lists showing the particulars of large works carried out and the names of manufacturers of specialised items as required under clauses 17 General Instructions to Contractors and Special Conditions are enclosed.

5. Our bankers are : (with full address)

i)

ii)

The names of partners of our firm are

i)

ii)

Name of the partners of the firm  
authorised to sign

Or

Name of person having power of  
Attorney to sign the Contract  
(Certified true copy of the Power of  
Attorney should be attached)

Your faithfully

(Signatures and addresses of witnesses)

(i)

(ii)

Signature of Contractor

## **GENERAL INSTRUCTIONS TO CONTRACTORS AND SPECIAL CONDITIONS**

Sealed Tenders in duplicate (original with photocopy) should be addressed to Shri Sukhbir Singh, Chief General Manager, National Bank for Agriculture and Rural Development, Mumbai (by name) and superscribed "Tender for the construction of RCC retaining wall & boundary wall at plot no. 24/7, Indira Nagar, Lucknow" for the National Bank for Agriculture and Rural Development at Indira Nagar, Lucknow and sent so as to reach him not later than 3 p.m. on 08.09.2008. National Bank for Agriculture and Rural Development hereinafter being referred as Employer. Tenderers should clearly indicate on each copy of the tender under their full signature whether it is the original or photocopy. Unsealed tenders will be rejected summarily.

1. No tender will be received after 3.00 p.m. on 08.09.2008 under any circumstances whatsoever.
- 2 (a) The Part-I of Tenders will be opened at 3.30 p.m. on 08.09.2008 at his office by Shri Sukhbir Singh, Chief General Manager, National Bank for Agriculture and Rural Development or any other officer designated for this purpose by him in the presence of the bidders or their representatives, should they choose to be present.
  - (b) Tenders shall remain open to acceptance by the Bank for a period of 120 days from the date of opening the Part-II of the tender which period may be extended by mutual agreement and the bidder shall not cancel or withdraw the tender during this period. In case if any bidder withdraws his tender before 120 days or makes any modification in the terms and conditions of the tender which are not acceptable to Employer then without prejudice to any other right or remedy, the Employer shall be at liberty to forfeit the said earnest money absolutely.
  - (c) The bidder must use only the forms issued by the Employer to fill in the rates.
- 3(a) The tender form must be filled in Hindi/English and all entries must be made by hand and written in ink. If any of the documents is missing or unsigned, the tender may be considered invalid by the Employer at its discretion.
  - (b) Rates should be quoted both in figures and words in columns specified and the amounts in figures only, in such a way that interpolation is not possible. The total amount should be written both in figures and in words. In case of figures, the words 'Rs.' should be written before the figure of rupees and the words 'P' after the decimal figures e.g. Rs. 3.16 P' and in case of words, the word Rupees should precede and the words 'Paise' should be written at the end. Unless the rates is in whole rupees and followed by the words 'only' it should invariably be upto two decimal places. While quoting the rate in schedule of quantities, the words 'only'

should be written closely following the amount and it should not be written in the next line.

If on check there are differences between the rates quoted by the bidder in words and in figures or in the amount worked out by him, the following procedure shall be following :

- i) when there is a difference between the rates in figure and in words, the rates which correspond to the amount worked out by the bidder shall be taken as correct.
- ii) when the amount of the item is not worked out by the bidder or it does not correspond with the rate written either in figure or in words, then the rate quoted by the bidder in words shall be taken as correct.
- iii) when the rate quoted by the bidder in figures and in words tallies but the amount is not worked out correctly, the rate quoted by the bidder shall be taken as correct and not the amount.

All erasures and alterations made while filling the tender must be attested by initials of the bidder. Overwhelming of figures is not permitted and failure to comply with either of these conditions will render the tender void at Employers option. No advice of any change in rate or conditions after opening of the tender will be entertained.

(c) Each of the tendered documents should be signed by the person or persons submitting the tender in token of his/their having acquainted himself/themselves with the General Instructions to Contractors and Special Conditions. Conditions of Contract, Additional Conditions and Additional Specifications, etc., as laid down. Any tender with any of the documents not signed will be liable for rejection.

(d) The tender submitted on behalf of a firm shall be signed by all the partners of the firm or by a partner who has the necessary authority on behalf of the firm to enter into the proposed contract, otherwise the tender may be rejected by the Employer.

(e) The tender for the work shall not be witnessed by a bidder/s who himself/themselves has/have tendered or who may and has/have tendered for the same work. Failure to observe this condition would render the tenders of the bidder tendering as well as witnessing the tender liable for summary rejection.

4. The Employer does not bind itself to accept, the lowest of any tender and reserve to itself the right to accept or reject any or all the tenders, either in whole or in part, without assigning any reasons for doing so. Tenders in which any of the prescribed conditions are not fulfilled or are incomplete in any respect are liable to be rejected.
5. "Intending bidders shall pay as Earnest Money Deposit a sum of Rs. 34000.00 (Rupees thirty four thousand only ) in cash or by a Demand Draft issued by a Scheduled Bank drawn in favour of 'National Bank for Agriculture and Rural Development' payable at Lucknow. Demand draft

may be directly attached to the tender. A tender, which is not accompanied by Demand Draft or cash as Earnest Money, will not be considered. The Earnest Money will be refunded to the bidder if his tender is not accepted and no interest will be payable by the Employer. Under no circumstances Earnest Money Deposit will be accepted in any other form.

6.(a) The Earnest Money Deposit paid by the successful bidder when he submitted his tender shall be held by the Employer as security for the execution and due fulfillment of the contract. No interest shall be paid on the said deposit. The Earnest Money Deposit shall be forfeited in case the successful bidder fails to commence the work awarded to him within the prescribed time limit or fails to execute the agreement as stipulated in Clause 8(a) hereinbelow or fails to pay the Initial Security Deposit as stipulated in Sub-Clause (b).

(b) 'Initial Security Deposit' of 2% of accepted value to tender shall be provided by the successful bidder in the form of cash or bank draft or bank guarantee from a scheduled bank within 15 days of intimation to him of acceptance of his tender. The EMD already furnished by the successful bidder shall be taken into account while determining the above ISD. The ISD will be liable to be forfeited in case the successful bidder commits breach of any of the terms and conditions of the contract or fails to complete the works. This forfeiture is without prejudice to the Employer's claim for liquidated damages as provided hereinafter.

(c) In addition to the Initial Security Deposit under Clause 7(b) and as further security for the due fulfillment of the contract by the Contractor. 3% of the value of the work done will be deducted by the Employer from each payment to be made to the Contractor towards Retention Money until the Retention Money and Initial Security Deposit together amounts to 5% of the accepted value of tender. This total amount will be termed as Security Deposit. This Retention Money/Security Deposit so deducted/collected will carry no interest. After the Bank issuing a virtual completion certificate' for all works, the Contractor would be refunded 50% of the Security Deposit and the balance will be released by Employer when all relevant certificates including clearance certificate from Labour Officer is obtained and after rectification of defects pointed out during the defects liability period or after completion of defects liability period whichever occurs later. While releasing the 50% of Security Deposit after virtual completion certificate, Bank will release the B.G. and retain the cash part. The amount retained by Employer shall not bear any interest.

(d) All compensation or other sums of money payable by the Contractor to the Employer under the terms of this contract may without prejudice to the Employer's rights under Law be deducted from the Security Deposit if the amount so permits and the Contractor shall, unless such deposit has become otherwise payable, within ten days after such deduction make good in cash the amount so deducted, failing which the Employer shall be entitled to deduct the same from any money due to the Contractor.

7. (a) On receipt of intimation from the Employer of the acceptance of his/their tender, the successful bidder shall be bound to implement the contract and within fourteen days thereof the successful bidder shall sign an agreement in accordance with the draft agreement and the Schedule of Conditions. The written acceptance by the Employer of a tender will constitute a binding contract between the Employer and the person so tendering, whether such formal agreement is or is not subsequently executed.

(b) On acceptance of the tender, the name of the accredited representative(s) of the Contractor who would be responsible for taking instructions from the bank's representative/engineer/Bank's Engineer shall be communicated to Employer.

8(a) The Contractor shall not sublet/assign any portion of the contract except with the written consent of the Employer. In case of breach of these conditions, the Employer may cause the Chief Engineer of the Employer to serve a notice in writing on the Contractor rescinding the contract whereupon the Security Deposit shall stand forfeited to the Employer or any other action which will be deemed fit.

9. **Specifications** —The entire work shall be done as per the latest CPWD specification with up to date correction slips. However, in the event of any discrepancy in the description of any item as given in Schedule of Quantities appended with the tender and the specifications relating to the relevant item as per latest CPWD specification, the former shall prevail. If the specifications for any item are not available in the latest CPWD specification, relevant IS specifications shall be followed. In case IS specifications are also not available, the decision of the Bank's Engineer given in writing based on sound Engineering practice and local usage shall be final and binding on the Contractor.

The work shall be executed and measured as per metric dimensions given in the Schedule of Quantities, drawings etc.

10(a) The Contractor's responsibility for the contract shall commence from the date of issue of orders of acceptance of tender. The Contractor shall carry out all the work strictly in accordance with Drawings, details and instructions.

(b) The structural and architectural drawings, shall at all time be properly correlated before executing any work. In case of any difference noticed between the Architectural and Structural drawings, final decision in writing of the Bank's Engineer/Site Engineer shall be obtained by the Contractor. For items where so required. Samples shall be prepared before starting the particular items of work for prior approval of Bank's Engineer/Site Engineer and nothing extra shall be payable on this account for sample preparation. However, in case of any discrepancy in the item given in the Schedule of Quantities appended with the tender and Architectural Drawings relating to the relating item, the former shall prevail unless and otherwise given in writing by the Bank's Engineer and such discrepancy should be brought to the notice of the Employer forthwith.

11. A Schedule of Quantities in respect of each work accompany these Special Conditions. The Schedule of Quantities is liable to alteration by omissions, deduction or additions at the discretion of the Employer/Architect. Each tender should contain not only the rates but also the value of each item of work entered in a separate column and all the items should be totaled in order to show the aggregate value of the entire tender.
12. The bidder must obtain for himself on his own responsibility and at his own expenses all the information which may be necessary for the purpose of making a tender and for entering into a contract and must examine the Drawings and must inspect the site of the work and acquaint himself with all local conditions, means of access to the work, nature of the work, working condition including stacking of materials, installation of T & P, conditions affecting accommodation and movement of labour etc. required for satisfactory execution of work. No claim whatsoever on such account shall be entertained by Employer in any circumstances.
13. The rates quoted in the tender shall include all charges for clearing of site before commencement as well as after completion, water, electric consumption, meters, double scaffolding, centering, box staging, planking, timbering and pumping out water including bailing, fencing, hoarding, plant and equipment, storage sheds, watch and ward and lighting, by night as well as day including Sundays and holidays, temporary plumbing and electric supply, protection of the public, public property and safety of adjacent roads, streets, cellars, vaults, ovens, pavement, wall, houses, buildings and all other erections, matters or things and the Contractor shall take down and remove any or all other erections, matters or things and the Contractor shall take down and remove any or all such centering, scaffolding, staging, planking, timbering, strutting, shoring etc., as occasion shall require or when ordered so to do and fully reinstate and make good all matters disturbed during the execution of work and to the satisfaction of the bank and in total compliance of all rules, regulations and laws. The rates quoted shall be deemed to be for the finished work to be measured at site. The rates shall also be deemed to be for the finished work to be measure at site. The rates shall also be firm and shall not be subject to exchange variations, labour conditions, fluctuations in railway freight or any conditions whatsoever. Bidders must include in their rates sales tax, excise duty, octroi, sales tax on works contract and any other tax and duty or other levy levied by the Central Government or any State Government or local authority, if applicable. No claim in respect of sales tax, excise duty, octroi or other tax, duty or levy whether existing or future shall be entertained by the Employer.
14. The Contractor should note that unless otherwise stated the tender is strictly on item rate basis and his attention is drawn to the fact that rates for each and every item should be correct, workable and self supporting. The quantities in the Schedule of Quantities approximately indicate the total extent of work but may vary to any extent and may even be omitted

thus altering the aggregate value of the contract. No claim shall be entertained on this account.

15. Time allowed for carrying out the work as mentioned in the Memorandum which includes monsoon months shall be strictly observed by the Contractor and it shall be reckoned from the 10th day after written order to commence the work, is issued. The work shall throughout the stipulated period of the contract be proceeded with all due diligence and if the Contractor fails to complete the work within the specified period, he shall be liable to pay compensation as defined in Clause 26 of the Conditions of Contract. The bidder shall before commencing work prepare a detailed work programme which shall be approved by the Bank and Employer.
16. The rate quoted by the Contractor shall include expenditure for providing all the water required for the work and the Contractor shall make his own arrangement for the supply of good quality water, including
  - a. The rate quoted in the tender shall also include electric consumption charges for power. If no power is available at the site, the Contractor shall have to make his own arrangements to obtain power connections and maintain at his own expense an efficient service of electric light and power and shall pay for the electricity consumed. The Employer, as well as the Bank may assist the Contractor to obtain the requisite permission from the various Authorities, but the responsibility for obtaining the same shall be that of the Contractor.
  - b. Unless otherwise provided in the Schedule of Quantities, the rates tendered by the Contractor shall be all inclusive and shall apply to all heights, lifts and leads and depths of the structure and nothing extra shall be payable to him on this account.
  - c. Unless otherwise specified in the Schedule of Quantities, the rates for all items of work shall be considered as inclusive of pumping out or bailing out water if required for which no extra payment will be made. This will include water from any source, such as rains, floods, sub-soil water table being high or due to any other cause whatsoever.
  - d. Rate of all items in which use of cement is involved is inclusive of charges for curing. Any cement slurry added over base surface (or) for continuation of concreting for better bond is deemed to have been in-built in items (unless otherwise explicitly stated) and nothing extra shall be payable (or) extra cement considered in consumption on this account.
17. All Municipal/statutory fees for drainage and water & electricity connection for construction purposes shall be borne by the Contractor. However, fees paid for permanent connections shall be reimbursed to the Contractor on production of receipts. Electric supply connection fees for the permanent supply will be paid by the Employer to the Electric supply authority, if needed.

The Contractor shall strictly comply with the provision of Safety Code annexed hereto.

18. CPWD specifications and all amendments as well as I.S. Code numbers wherever mentioned in the tender shall be the latest version of CPWD specifications I.S. codes respectively as on the date of opening of Tenders.

**19. Programme of work :**

The Contractor shall be required to submit a schedule for completion of work, either in the form of a CPM net work or in the form of a BAR chart or if the Employer permits as a special case in the form of Bar chart showing how he proposes to complete the works, within fifteen days of the date of start of work. This programme shall be prepared in sufficient detail and shall indicate, among other things, the following details on a month-to-month basis (for each month).

**20. Tenderer to Inform Himself fully :**

The Contractor shall be deemed to have carefully examined the work and site conditions including labour, the general and special conditions, the specifications, schedule and drawings and shall be deemed to have visited the site of work. to have fully informed himself regarding the local conditions and carried out his own investigations to arrive at the rates quoted in the tender. In this regard he will be given necessary information available with the department but without any guarantee about its accuracy.

If the Contractor shall have any doubt as to the meaning of any portion of the generals conditions, or the special conditions or the scope of the work or the specifications and drawings or any other matter concerning the contract, he shall in good time, before submitting his tender put forth the particulars thereof and submit them to the Employer at the office of C.G.M., NABARD, Regional Office, Lucknow in writing in order that such doubts may be clarified authoritatively in writing before tendering. Once a tender is submitted, the matter will be decided according to the tender conditions in the absence of such authentic pre-clarification.

**21. Errors, Omission and Descriptions**

(a) In case of errors, omissions and/or disagreement between written and scaled dimensions on the drawings or between the drawings and specifications etc. the following order of preferences shall apply

- i. Between actual scaled and written dimension (or description) on a drawing the latter shall be adopted.
- ii. Between the written or shown description or dimensions in the drawings and the corresponding one in the specification the latter shall be taken as correct.

- iii. Between the written description of the item in the specification and the detailed descriptions in the schedule of quantities of the same item the latter shall be adopted.
- iv. Between the written description of the item in the specification and the detailed description in the additional specification of the same item, the latter shall be adopted.
- (b) In all cases of omissions and/or doubts or discrepancies in any item or specification a reference shall be made to the General Manager/DGM (Premises Department) of NABARD whose elucidation, elaboration or decision shall be considered as authentic. The Contractor shall be held responsible for any errors that may occur in the work through lack of such references and precaution.

I/We hereby declare that I/We have read and understood the above instructions for guidance of bidders.

Witness : Signature of bidder \_\_\_\_\_

Date : Address \_\_\_\_\_

\_\_\_\_\_  
Date : \_\_\_\_\_

## 22. SAFETY CODE:

1. First aid appliances including adequate supply of sterilised dressing and cotton shall be kept in readily accessible places.
2. An injured person shall be taken to a public hospital without loss of time, in cases where the injury necessitated hospitalisation.
3. Suitable and strong scaffolds should be provided for workmen for all works that cannot safely be done from the ground
4. No portable single ladder shall be over 8 meters in length. The width between the rails shall not be less 30 cm. (clear) and the distance between two adjacent rungs shall not be more than 30 cm. When a ladder is used an extra mazdoor shall be for holding ladder.
5. The excavated material shall not be placed within 1.5 metres of the edge of the trench or half of the depth of trench whichever is more. All trenches and excavations shall be provided with necessary fencing and lighting.
6. Every opening in the wall or in a working platform be provided with suitable means to prevent the fall of persons or materials by providing suitable fencing or railing whose minimum height shall be one metre.
7. No part of the structure shall be so overloaded with debris or materials, as to render it unsafe.
8. Workers employed on mixing and handling material such as asphalt, cement mortar of concrete and lime mortar shall be provided with protective footwear and rubber hand gloves.
9. Those engaged in welding works shall be provided with welder's protective eye-shields and gloves.
10. (i) No paint containing lead or lead products shall be used except in the form of paste or ready made paint.  
(ii) Suitable facemasks should be supplied for use by the workers when the paint is applied in the form of spray or surface having lead paint dry rubbed and scrapped.
11. Overalls shall be supplied by the Contractor's to the painters and adequate facilities shall be provided to enable the working painters to wash during the period of cessation of work.
12. Hoisting machines and tackle used in the works, including their attachments, anchorage and supports shall be in perfect condition.
13. The ropes used in hoisting or lowering material or as a means of suspension shall be of durable quality and adequate strength and free from defects.

## Conditions of Contract

### 1. INTERPRETATIONS :

In construing these Conditions, Additional conditions, Specifications and Additional specifications, Schedule of Quantities and Contract Agreement, the following words shall have the meanings herein assigned to them except where the subject or context otherwise requires :

a. "Owner"/"Employer"/"Client" shall mean National Bank for Agriculture and Rural Development (NABARD) with its Head Office at Bandra Kurla Complex, Mumbai and Regional Office at 11, Vipin Khand, Gomti Nagar, Lucknow and shall include his/their heirs, legal representatives, assignees and successors.

b.

"Contractors"  
In the case of a  
partnership  
firm

"Contractor shall mean \_\_\_\_\_  
\_\_\_\_\_  
\_\_\_\_\_  
and \_\_\_\_\_ trading as partners in the name  
and style of \_\_\_\_\_  
\_\_\_\_\_  
\_\_\_\_\_  
and having a place of business at \_\_\_\_\_  
\_\_\_\_\_  
and shall include the partners for the time being of the  
said firm and the legal representatives of a deceased  
partner.

In the case of  
Individuals

"Contractor" shall mean \_\_\_\_\_  
trading in the name and style of \_\_\_\_\_  
\_\_\_\_\_  
\_\_\_\_\_  
and shall include his heirs, successors and legal  
representatives.

In the case of  
company

"Contractor" shall mean \_\_\_\_\_  
a company incorporated under \_\_\_\_\_ 19 and  
having its registered office at \_\_\_\_\_ and shall  
include its successors and assignees.

- c. "Works" shall mean the works to be executed and recorded in accordance with the contract and shall include all extra, additional, altered or substituted works as required and recorded for the performance of the contract. No claim for payment of such extra work shall be allowed unless the said work shall have been executed under the provisions of Clause-5 (Authorities, patents, Rights & Royalties) and by directions in writing of the Bank.
- d. "Contract Documents" shall include the Tender notice, Form of tender, the Articles of Agreement, the General Instruction to Contractor and Special conditions, Conditions of contract, Additional conditions, Specification, Additional specifications, the Annexures & Appendix, the Schedules of Quantities, and drawings pertaining to the work. All sections of this Contract Document are to be read together.
- e. "Notice in Writing" or written notice shall mean a notice in writing, typed or printed characters, sent (unless delivered personally) or otherwise, proved to have been sent by registered post to the last known private or business address or registered office of the addressee and shall be deemed to have been received when in the ordinary course of post it would have been delivered.
- f. "Act of Insolvency" shall mean any Act of Insolvency as defined by the Presidency Towns Insolvency Act, or the Provincial Insolvency Act or any Act amending such original.
- g. "Virtual Completion" shall mean that the works are complete in all respect.
- h. Words importing persons including firms and Corporations, words importing male gender also include female and words importing the singular only also include the plural and vice-versa where the context requires.
- i. Headings and marginal notes to these conditions shall not be deemed to form a part thereof or be taken into consideration in the interpretation or construction thereof or of the contract.
- j. "Site" shall mean the land and/or other places on, into or through which work is to be executed under the contract or any adjacent land, path or street through which the work is to be executed under the contract or adjacent land, path or street which may be allotted or used for the purpose of carrying out the contract.
- k. Net Prices                      If in arriving at the contract amount the Contractor shall have added to or deducted from the total of the items in the Tender any sum, either as a percentage or otherwise, then the net price of any item in tender shall be the sum arrived at by adding to or deducting from the actual figure appearing in the Tender as the price of that item a similar percentage or proportionate sum provided always that in determining the percentage or proportion of the sum so added to or deducted by the

Contractor the total amount of any Prime Cost items and provisional sums of money shall be deducted from the total amount of the tender. The expression "net rates" or "net prices" when used with reference to the contract or accounts shall be held to mean rates or prices so arrived at.

## **2. SCOPE OF CONTRACT :**

The Contractor shall carry out and complete the works in every respect in accordance with this contract and with the directions of and to the satisfaction of the Bank/Employer. The Bank may in absolute discretion and from time to time issue further drawings and/or written instructions, details, directions and explanations which are hereafter collectively referred to as "instructions" reflected either in the minutes or in any other form in regard to :

- a. The variation or modification of the design quality or quantity of works or the addition or omission or substitution of any work.
- b. Any discrepancy in or divergence between the Drawings or between the Schedule of quantities and/or Drawings and/or specifications.
- c. The removal from the site of any material brought thereon by the Contractor and the substitution of any other materials thereof.
- d. The removal and/or re-execution of any works executed by the Contractor.
- e. The postponement of any work to be executed under the provisions of this contract.
- f. The dismissal from the works of any person employed thereupon.
- g. The opening up for inspection of any work covered up.
- h. The amending and making good of any defects.
- i. Co-ordination of work with other agencies.

The Employer shall have a right to delete any item of work from the scope of contract and Contractor shall not make any extra claim on this account.

The Contractor shall forthwith comply with and duly execute any work comprised in such Bank instructions provided always that verbal instructions, directions and explanations given to the Contractor or his representative upon the works by the Bank shall, if involving a variation, be confirmed in writing by the Contractor within 7 days, and if not dissented from in writing within a further 7 days by the Bank such shall be deemed to be the Bank instructions within the scope of the contract.

**Contractor to provide everything necessary at his cost :**

3(a) The Contractor shall provide at his cost everything necessary for the proper execution of the works according to the intent and meaning of the Drawings, Schedule of Quantities Specification, and Additional Specification taken together with whether the same may or may not be particularly shown or described therein provided that the same can reasonably be inferred therefrom, and if the Contractor finds any discrepancy in the Drawings or between the Drawings, Schedule of Quantities, Specifications and Additional Specifications, he shall immediately and in writing refer same to the Banks who shall decide which is to be followed.

All materials including steel and cement shall be purchased by the contractor himself. The materials shall be required to be tested from laboratories approved by the Architects/ bank's representative/engineer/Bank as per provisions as of relevant IS codes and the testing charges shall be borne by the contractor.

The contractor shall provide and maintain a site laboratory as a facility for carrying out routine testing of materials. He shall also provide and maintain all measuring and surveying instruments, including steel tape, theodolite and dumpy level at all times for properly carrying out the work and for the use of the PNC/employer, including skill attendants as required.

**(b) Diversion of Road, Nulla Etc. :**

The Contractor shall, wherever necessary for execution of the work, divert the existing roads or nullah, if any, at his own cost without causing any hindrance to the through fare. No extra payments shall be made for his work. In all such cases, the Contractor shall restore the road or nullah to its original condition for which no extra payment will be made.

**(c) Keeping the Areas and Access Roads clean :**

The Contractor shall be required to maintain the site and the buildings areas in a neat and clean condition at all time to the satisfaction of the bank's representative/engineer. The Contractor shall especially take care to keep areas free from getting water logged, from Concrete/mortar dippings, bricks, steel, shuttering materials or any other material/rubbish. No extra payment for such works will be payable to the Contractor.

**(d) Labour Hutment :**

The Contractor shall not be allowed to put up any hutment/temporary structure for accommodating his labour/staff. He shall be required to make these arrangements elsewhere at his own cost. However, if the rules of local authorities so permit, some space at site which will not come in way of permanent construction could be given at the sole discretion of the Employer and on a purely temporary basis.

**4. Authorities, Notices, Patent, Rights & Royalties :**

The Contractor shall conform to the provision of any Act of the Legislature relating to the work, and to the regulations and bye-laws of any authority, and of any water, electric supply and other companies and/or authorities with whose systems the structure is proposed to be connected, and shall, before making any variations from the Drawing or Specifications that may be necessitated by so conforming, give to the Bank written notice, specifying the variation proposed to be made and the reasons for making it and apply for instructions. He shall proceed with the work conforming to the provisions, regulations or bye-laws in question, and any variation so necessitated shall be dealt with under Clause 13 hereof.

The Contractor shall bring to the attention of the Bank all notices required by the said Acts, regulations or bye-laws to be given to any authority and pay to such authority or to any public office all fees, Royalties that may be properly, charged or chargeable in respect of the works, and lodge the receipts with the Bank.

The Contractor shall indemnify the Employer against all claims in respect of patent rights and shall defend all actions arising from such claims, and shall himself pay all royalties, license fees, damages cost and charges of all and every sort that may be legally incurred in respect thereof.

**5. Setting out of works :**

The Contractor shall at his own expense, set out the works and shall be solely responsible for the true and perfect setting out of the same and for the correctness of the positions, levels, dimensions and alignment of all parts thereof. If at any time any error in this respect shall appear during the progress of the works or within a period of one year from the completion of the works, the Contractor shall, if so required, at his own expense rectify such error to the satisfaction of the Bank. The contractor will employ service of qualified architect/engineer for the work.

**6. Materials and workmanship to conform to descriptions :**

All materials and workmanship shall so far as procurable be of the respective kinds described in the Schedule of Quantities and/or Specifications/Additional Specifications and in accordance with the Bank's instructions, and the Contractor shall upon the request of the Bank furnish him with all invoices, accounts, receipts and other vouchers to prove that the materials comply therewith. The Contractor shall at his own cost arrange for and/or carry out any test of any materials which the Banks may require. For establishing the soundness and efficiency, if after any such test, the work or portions of the work are found to be defective or unsound, the Contractor shall put down and reerect the same at his cost and no payment will be made on this account by the Employer.

**7. Contractor's superintendence and representative on the Works :**

The Contractor shall give all necessary personal superintendence during the execution of the works, and as long thereafter as the Bank may consider

necessary until the expiry of the "Defects Liability Period" stated in the appendix hereto. The Contractor shall also during the whole time the works are in progress employ a competent qualified and experienced Engineer/s who shall be constantly in attendance at the works while the men are at work. Any directions, explanations, instructions or notices given by the Bank to such representative/s shall be held to be given to the Contractor.

#### **8. Dismissal of Workman :**

The Contractor shall on request of the Bank immediately dismiss from the works any person employed thereon by him who may, in the opinion of the Bank, be incompetent or misconduct himself and such persons shall not be again employed on the works or allowed to enter the work site without the permission of the Bank/Employer.

#### **9. Access to Works**

The Employer, the Bank and their respective representatives shall at all reasonable times have free access to the work and/or to the workshops, factories or other places where materials are lying or from which they are being obtained and the Contractor shall give every facility to the Employer, the Bank and their representatives necessary for inspections and examination and test of the materials and workmanship. No person not authorised by the Employer or the Bank except the representatives of public authorities shall be allowed on the works at any time.

#### **10. Assignment and subletting :**

The whole of the works included in the contract shall be executed by the Contractor and the Contractor shall not directly or indirectly transfer, assign underlet the contract or any part/share thereof or any interest therein without the prior written consent of the Employer; and no undertaking shall relieve the Contractor from the full and entire responsibility of the contract or from active superintendence of the works during their progress.

#### **11. Alterations, additions, omissions etc.**

No alteration, addition, omission or variation shall vitiate this contract and therefore case the Bank thinks proper at any time during the progress of the works to make any alterations in or additions to, or omissions from, the works or any alteration in the kind or quality of the materials to be used therein, shall give notice thereof in writing under this head to the Contractor. The Contractor shall alter, add to, or omit from as the case may be, in accordance with such notice, but the Contractor shall not do any work extra to or make any alterations or additions to or omissions from the works or any deviation from any of the provisions of the contract stipulation, Specifications or Contract Drawings without the previous consent in writing of the Bank and the value of such extra, alterations, additions, or omissions shall in all cases be determined by the Bank as per Clause 17 hereof, and the same shall be added to or deducted from the Contract Amount, as the case may be.

## **12. Schedule of Quantities :**

The Schedule of Quantities, unless otherwise stated shall be deemed to have been prepared in accordance with the standard method of measurement.

Any error in description or in quantity or in omission of items from the Schedule of Quantities shall not vitiate this contract but shall be rectified and the value thereof as ascertained under clause 17 hereof, shall be added to, or deducted, from the Contract Amount (as the case may be) provided that no rectification of errors, if any, shall be allowed in the Contractor's Schedule of Rates.

## **13. Sufficiency of Schedule of Quantities**

The Contractor shall be deemed to have satisfied himself before tendering as to the correctness and sufficiency of his tender for the works and of the prices stated in the Schedule of Quantities and/or the Schedule of Rates and prices which rates and prices shall cover all his obligations under the contract, and all matters and things necessary for the proper completion of the works.

## **14. Opening up works :**

- a). The Contractor shall notify the bank's representative/engineer in writing immediately when the trenches or excavation shown on drawings are got ready or as soon as any ground is cut into, which from unexpected causes, appears to need immediate attention. After notifying the bank's representative/engineer he shall await instructions which shall be given within seven days of receipt of such notice. If the Contractor put in any parts of the foundation before he has so notified the bank's representative/engineer and received instructions, he shall be liable to reinstate all work that may subsequently be, at any time, damaged on account of any defect in or insufficiency of the foundations. The Contractor shall, at request of the bank's representative/engineer within such time as the bank's representative/engineer shall name open up for inspection any other work and should the Contractor refuse or neglect to comply with such requests, the Employer through the bank's representative/engineer may employ the other workmen to open up the same. If the said work has been covered up in contravention of the Banks instructions, or if on being opened up it be found not in accordance with the drawings, and specifications/additional specification, or the instructions of the Banks instructions, or if on being opened up it be found not in accordance with the drawings, and specifications/additional specification, or the instructions of the Bank, the expenses of opening and covering it up again, whether done by the Contractor or such other workmen shall be borne by and recoverable from the Contractor, or may be deducted from any money due or which may become due to the Contractor. If the work has not been covered up in contravention of such instructions, and be found in accordance with the said drawing and specifications/additional or instructions, then the expenses aforesaid shall be borne by the Employer and be added to the contract sum, provided always that in the case of foundation, or of any other work so opened up and requiring immediate

attention the bank's representative/engineer shall within seven days after receipt of written notice from the Contractor that the work has been opened, make or cause the inspection thereof to be made, and the expiration of such time, if such inspection shall not have been made the Contractor may cover up the same, and shall not be required to open it up again, except at the expense of the Employer.

### **Measurement of Works**

- b. The Bank may from time to time intimate to the Contractor that he requires the works to be measured, and the Contractor shall forthwith attend or send, a qualified Agent to assist Site Engineer/ representative of bank in taking such measurements and calculations and to furnish all particulars or to give all assistance required by any of them.

Should the Contractor not attend or neglect or omit to send such agent then the measurement taken by the Bank or a person approved by him shall be taken to be correct measurements of the works. Such measurements shall be taken in accordance with the mode of measurements detailed in the Specifications/Additional Specifications.

The Contractor or his Agent may at the time of measurement take such notes and measurements as he may require.

All authorised extra works, omissions and all variations made without the Banks knowledge, but subsequently sanctioned by him in writing (with the prior approval in writing of the Employer) shall be included in such measurements.

### **Measurement to be recorded before work is covered up :**

- c. The Contractor shall take joint measurements with the bank's representative/engineer before covering up or otherwise placing beyond the reach of measuring items of work.

### **15. Prices for extras etc. ascertainment of**

The Contractor may, when authorised, and shall, when directed, in writing by the Bank with the approval for the Employer add to, omit from or vary the works shown upon the drawings or described in the specifications/additional specifications, or included in the Schedule of Quantities, but the Contractor shall make no addition, omission or variation without such authorisation or direction. A verbal authority or direction by the Banks shall, if confirmed by them in writing within seven days, be deemed to have been given in writing.

No claim for an extra shall be allowed unless it shall have been executed under provisions of Clause 5 hereof or by the authority of the Banks with the concurrence of the Employer as herein mentioned. Any such extra is herein referred to as authorised extra and shall be made in accordance with the following provisions :

- a. i) The net rates or prices in the original tender shall determine the valuation of the extra work where such extra work is of similar character and executed under similar conditions as the work priced therein.

ii) Rates for all items, wherever possible, should be derived out of the rates given in the Priced Schedule of Quantities/DSR 2007.

**16. Removal of improper work :**

a . The Bank shall, during the progress of the works, have power to order in writing from time to time the removal from the works within such reasonable time or times as may be specified in the order, of any materials which in the opinion of the Bank are not in accordance with the Specifications/additional specifications or instruction of the Bank, the substitution of proper materials, and the removal and proper re-execution of any work executed with materials or workmanship not in accordance with the Drawings and Specifications/additional specifications or instructions; and the Contractor shall forth with carry out the same, and all expenses consequent thereon, or incidental thereto, as certified by the Bank shall be borne by the Contractor, or may be deducted by the Employer from any moneys due, or that may become due to the Contractor.

**Removal of all offensive matters :**

b. All soil, filth or other matter of an offensive nature taken out of any trench, sewer, drain, cess-pool or other place shall not be deposited on the surface, but shall be at once carried away by the Contractor to some pits or place provided by him and shall be disposed off as per the rules and regulations of the local Authorities concerned.

**17. Defects after virtual completion**

Any defect, shrinkage, settlement or other faults which may appear within the "Defects Liability Period" stated in the Appendix hereto or, if none stated, then within twelve months after the virtual completion of the works, arising in the opinion of the Bank from materials or workmanship not in accordance with the contract, shall upon the directions in writing of the Bank, and within such reasonable time as shall be specified therein, be amended and made good by the Contractor, at his own cost and in case of default the Employer may employ and pay other persons to amend and make good such defect, shrinkage, settlements or other faults and all damages loss and expenses consequent thereon or incidental thereto shall be made good and borne by the Contractor and such damage, loss and expenses shall be recoverable from him by the Employer or may be deducted by the Employer, upon the Bank's Certificate in writing from any money due or that may become due to the Contractor, or the Employer may in lieu of such amending and making good by the Contractor deduct from any moneys due to the Contractor a sum, to be determined by the Bank equivalent to the cost of amending such work and in the event of the amount retained under Clause 31 hereof being insufficient, recover the balance from the contractor, together with any expenses the Employer may have incurred in connection therewith. Should any defective work have been done or material supplied by any sub-contractor employed on the works who has been nominated or approved by

the Bank as provided in clause 12 and 22 hereof, the Contractor shall be liable to make good in the same manner as if such work or material had been done or supplied by the Contractor and been subject to the provisions of this Clause and Clause 2 hereof. The Contractor shall remain liable under the provisions of this Clause notwithstanding the signing of any certificate or the passing of any accounts, by the Bank.

#### **18. INFORMATION TO BE SUPPLIED/OBTAINING OF PERMISSION BY THE CONTRACTOR**

- a) The Contractor shall furnish the Employer the following :
- i. Detailed industrial statistics regarding the labour employed, due wages payment certificate, accidents of labour etc.
  - ii. Fortnightly statement of work done, skilled and unskilled labour employed cement and steel consumed etc.
  - iii. Display the permission licenses, registration certificate and other statements required to be displayed under various labour laws and other legislation applicable to works at the site office.
  - iv. Maintenance of all registers as per Annexure-I and records upto date and ready for inspection by the concerned authorities and also for bank's representative/engineer/Bank's Engineer.
19. Any treasure, fossils, minerals, works of art or antiquity be found during excavation or while carrying out the works, the same shall be the property of the Employer. The Contractor shall give immediate notice to the Bank of any such discovery and shall hand over any such treasure to the Employer on demand.

#### **20. Insurance in respect of damages to persons and property**

The Contractor shall be responsible for all injury or damage to persons, animals or things, and for all damage to property which may arise from any factor or omission on the part of the Contractor or any Sub-Contractor or any nominated Sub-Contractor or any of their employees. The liability under this clause shall cover also interalia any damage to structures, whether immediately adjacent to the works or otherwise; any damage to roads, streets, footpaths, bridges as well as damage caused to the building and other structures and works forming the subject matter of this contract. The Contractor shall also be responsible for any damage caused to the buildings and other structures and works forming the subject matter of this contract due to rain, wind, frost or other inclemency of weather. The Contractors shall indemnify and keep indemnified the Employer and hold him harmless in respect of all and any loss and expenses arising from any such injury or damage to persons or property as aforesaid and also against any claim made in respect of injury or damage, whether under any statute or otherwise and also in respect of any award or compensation or damage consequent upon such claims. The Contractor shall, at his own expense, effect and maintain till

issue of the Virtual Completion Certificate under this contract , with an insurance company approved by the Employer, an CAR (Contracter's all risk) for Insurance for the full amount of the contract including earthquake risk in the joint names of the Employer and the Contractor (the name of the former being placed first in the policy) against all risk as per standard all risk policy for Contractors and deposit such policy or policies with the Employer before commencing the work.

The contractor shall not commence any work at site until all the Insurance Policies, as required in terms of the Special/Additional Conditions and Conditions of Contract, have been submitted to the Employer, Renewal of the same if required due to extension of time for completion or similar reasons is also the responsibility of the Contractor.

Notwithstanding anything to the contrary mentioned in the contract, Contractors have to submit all Insurance Policies to the Clients directly to make the Client satisfy themselves regarding adequacy of values of Insurance, validity etc. as per contractual clauses.

- a. From commencement to completion of works, the Contractor shall take full responsibility for the care of the work and for taking precautions to prevent loss or damage to the work to the maximum extent possible and shall be liable for any damage or loss that may arise to the works or any part thereof from any cause whatsoever including causes of lightning, explosion, earthquake, storm, hurricane, floods, inundation, subsidence, landslides, rock slides, riots (excluding civil war, rebellion, revolution and insurrection) or any latent defect and shall be in good order and condition and in conformity in every respect with the requirements of the contract.
- b. The Contractor shall at all times indemnify and keep indemnified the Employer against all losses, claims, damages, or compensation under the provisions of the payment of the Wages Act 1936, Minimum Wages Act 1948. Employer's Liability Act 1938. Workman's Compensation Act 1923, the Maternity Benefit Act 1961, the Bombay Shops and Establishments Act 1947, Industrial Disputes Act 1947, and Contract Labour (Regulation and Abolition) and Employees State Insurance Act 1948. Inter State Migrants Workmen (Regulation of Employment) and Conditions of Services Act 1979 or any modification thereof or any other law relating thereto and rules made thereunder from time to time or as a consequence of any accident or injury to any workman or other person in or about the work whether in the employment of the Employer or Contractor or not, and also against all costs, charges and expenses of any suit, action or proceedings whatsoever out of such accident or injury or combination of any such claims.
- c. Before commencing the work, the Contractor shall without limiting his obligations and responsibilities under this conditions, insure against any loss of life or injury to any personnel in the employment of Contractor/Sub-Contractor/nominated Sub-contractor. Such an insurance shall be taken to include both employees/workmen covered by the Workman's

Compensation Act 1923, as well as those employees/workmen not covered by the said Act. Separate insurance policies may be taken for employees/workmen covered by Workman's Compensation Act 1923, and employees/workman not covered by the said Act. All the premia shall be paid by the Contractor. Policy/Policies taken under this para for the personnel in employment with the Contractor/Sub-contractor may be in their Employers' name of the Contractor/Sub-Contractor/nominated Sub-Contractors. In the even of any loss or injury to personnel in employment with the Contractor/Sub-Contractor/nominated Sub-Contractors, the Employee and Contractor shall recover directly from the Insurance Company and ensure that payment of the same is made to the affected parties. The policy in original shall be deposited with the Employer.

- a) The Contractor shall at all times indemnify and keep indemnified the Employer against all losses and claims for injuries or damage to any person or any property whatsoever which may arise out of or in consequence of the construction and maintenance of the work and against all claims demands, proceedings, damages, costs, charges and expenses whatsoever in respect of or in relation thereto. Before commencing the execution of the works, the Contractor shall without in any limiting his obligations and liabilities under these conditions, obtain insurance at his cost and expense against any damage or loss or injury which may be caused to any person or property including the employee or servants of the Employer and the Consultants and their property by or in the course of the execution of the work. Such insurance to be known as the Third Party Insurance shall be in a sum equivalent to two percent of the estimated value of the work, subject to the minimum sum of Rupees two lakhs. The Insurance policy to be so obtained by the Contractor shall be deposited by the Contractor with the Employer within seven days of the issue by the insurer.
- b) The Contractor shall provide the Employer with documentary evidence from time to time that he has taken all the insurance policies mentioned in the forgoing paragraphs and that he has paid the necessary premia for keeping the policies valid till the works are completed and handed over to Employer.
- c) Without prejudice to any of its obligations and responsibilities under this condition, the Contractor shall, within 30 days from the date of issue of the Work Order and thereafter at the end of each quarter submit a report to the Employer in Annexure V annexed hereto the detailed information on the Insurance Policies as prescribed in the said Annexure together with relevant documentary evidence.
- d) No work shall be commenced by the Contractor unless and until he has obtained the insurance or insurances required to be obtained by him under or by the foregoing clauses and no work shall be carried out or continued by the Contractor unless and until such insurance is current and valid at that time. All the receipts in original along with two photo copies thereof, for the payment of the premia shall be furnished by the Contractor to the

Employer. The original receipts will be returned to the Contractor after verification. The Employer reserves the right for payment on works done subject to fulfillment of this condition and shall instruct the Bank accordingly.

- e) In the event of any claim for insurance becoming the due on account of any eventuality covered by the respective insurance policy/policies, the Contractor shall reinstate the installation, replace the materials or equipments or pay compensation to the affected personnel/employees without waiting for settlement of the claim from insurance company.
- f) If the Contractor does not perform and observe any of the duties and obligations devolving upon him, hereunder, and such omission or breach by the Contractor shall involve the Employer in any liability, tortuous or otherwise and/or loss or damage, the Employer shall be entitled to the restitution of such loss or damage and shall be entitled to recover the amount of restitution from any moneys due to the Contractor from the Employer under this contract or any other contract.
- g) Upon occupation of building the Clients shall take out parallel insurance, to insure all persons who are not the Contractor's or the Sub-Contractor's or the nominated Sub-Contractors or the Project Management Consultant's staff or the agent of the Employers authorised representatives on getting the occupation certificate, the Clients will maintain their own insurance Policy and the Contractors will cease to be responsible for the insurance..
- h) The Contractor in case of rebuilding or reinstatement after damage shall be entitled to such extensions of time for completion as the Bank may deem fit, but shall however, not be entitled to reimbursement by the Employer of any shortfall or deficiency in the amount finally paid by the insurer in settlement of any claim arising as set out herein. No payment shall be made to the Contractor for any damage caused by rain, snowfall, floods or any other natural cause whatsoever during the execution of the work. The damage to work will be made good by the Contractor at his own cost and no claim on this account shall be entertained.

## 21. DATE OF COMMENCEMENT AND COMPLETION

- a) The Contractor shall be allowed admittance to the site on the "Date of Commencement" stated in the Appendix hereto, or such later date as any be specified by Bank and he shall thereupon begin the works within ten working days from the date of issue of work order and shall regularly proceed with and complete and same (except such painting or other decorative work as the Bank may desire to delay) on or before the "Date of Completion" state in the Appendix subject nevertheless to the provisions for extension of time hereinafter contained.
- b). **Certificate of Virtual completion & Defects liability period** : The work shall not be considered as completed until the Bank has certified in writing that they have been virtually completed. The Defects liability period shall

commence from the date of issue of such certificate and it will be twelve months or any other period stipulated in Appendix from such date.

**22. Damages for delay in completion :**

If the Contractor fails to complete the works by the date named in Appendix Date of completion) or within any extended time under clause 27 (Extension of Time) and if the Bank shall certify in writing on or before the date of issue of the Certificate for the last payment to which the Contractor may become entitled here under that the works could reasonably have been completed by the date or within the said extended time then the Contractor shall pay or allow the Employer the sum to be worked out as 0.25% of contract price per week to be recovered as Liquidated Damages (and not by way of penalty) for the delay, beyond the said date or extended time, as the case may be during which the works shall remain unfinished and such damages may be deducted from any moneys due or which may become due to the Contractor. The maximum amount of Liquidated damages shall be 5% of accepted tendered amount.

**23. Delay and Extension of time :**

If in the opinion of the Bank the works be delayed (a) by force majeure or (b) by reason of any exceptionally inclement weather or (c) by reason of proceedings taken or threatened by or dispute with adjoining or neighbouring owners or public authorities arising otherwise than through the Contractor's own default or (d) by the works or delays of other Contractors or Trades man engaged or nominated by the Employer or the Bank and not referred to in the Scheduled of Quantities and/or Specification/Additional specifications or (e) by reason of Bank's instruction as per Clause 2 hereof or (f) by reason of civil commotion, local commotion of workmen or strike or lockout affecting any of the building trades or (g) in consequence of the Contractor not having received in due time necessary instructions from the Bank for which he shall have specifically applied in writing or (h) from other causes which the Bank may certify as beyond the control of Contractor or (i) in the event, the value of the work exceed the value of the Priced Schedule of Quantities owing to variation, the Bank may with previous approval in writing of the Employer make a fair and reasonable extension of time for completion of the Contract works. In case of such strike or lock out the Contractor shall immediately give written notice thereof to the Bank but the Contractor shall nevertheless constantly use his endeavours to prevent delay and shall do all that may reasonably be required to the satisfaction of the Bank to proceed with work.

If the Contractor needs an extension of time for the completion of the work or if the completion or work gets delayed for any reasons beyond the due date of completion stipulated in the contract, the Contractor shall apply to the Employer for extension of time in writing at least 7 days before the expiry of the scheduled time and while applying for extension of time Contractor shall furnish the reasons in detail and his justification, if any, for delays. Only that period of extension of time as granted by the Employer (on receipt of the

application from the Contractor or even in absence of any such application) will qualify for consideration of exemption of imposition of liquidated damages. For the balance period in excess of original stipulated period excluding authorised extension of time granted by the Employer, the provision of damages as stated under Clause-26 will be applicable.

Further the contract shall remain in force even for the period beyond the due date of completion irrespective whether the Contractor has applied or not, for the grant of extension of time for completion unless the Employer decides to terminate the contract. The delay in completion of work for any reason will not entail any right to the Contractor to claim any revision of rates or any extra compensation for any reason.

**24. Failure by Contractor to comply with Bank Instructions :**

- (a) If the Contractor after receipt of written notice from the Bank requiring compliance within seven days fails to comply with such further drawings and/or Bank's instructions the Employer may employ and pay other persons to execute any such work whatsoever that may be necessary to give effect thereto, and all costs incurred in connection therewith shall be recoverable from the Contractor by the Employer on the Certificate of the Bank as a debt or may be deducted by him from any money due to the Contractor.
- (b) **Suspension of works :** If the Contractor except on account of any legal restraint upon the Employer preventing the continuance of the works, on account of any of the causes mentioned in Clause 27 (Delay & Extension of time) in the case of certificate being withheld or not paid when due, shall suspend the works, or in the opinion of the Bank, shall neglect or fail to proceed with due diligence in the performance of his part of the contract or if he shall more than once make default in the respects mentioned in Clause 19 (Removal of improper work and materials), the Employer through the representative shall have power to give notices in writing to the Contractor requiring that the works be proceeded within a reasonable manner and with reasonable dispatch. Such notices shall not be unreasonably given and must signify that it purports to be a notice under the provisions of this clause and must signify the act or defaults on the part of the Contractor upon which it is based. After such notice shall have been given, the Contractor shall not be at liberty to remove from the site of work, or from any ground contiguous thereto, any plant or materials belonging to him which shall have been placed thereon for the purpose of the works, and the Employer shall have lien upon such plant and materials to subsist from the date of such notice being given until the notice shall have been complied with. If the Contractor shall fail for 7 (seven) days after such notice has been given to proceed with the works as therein prescribed, the Employer may enter upon and take possession of the work and of all such plant and materials thereon intended to be used for the work, and the Employer shall retain and hold a lien upon all such plant and materials until the works shall have been completed under powers hereinafter conferred upon him. If the Employer shall exercise the above power, he

may engage any other person to complete the works and exclude the Contractor, his agents and servants, from entry upon or access to as the same, except that the Contractor or any person appointed in writing may have access at all reasonable times during the progress of the work to inspect, survey and measure the works. Such written appointment or a copy thereof shall be delivered to the employer before the persons appointed comes on to the works, and the Employer shall take such steps as in the opinion of the Bank may be reasonably necessary for completion of the works, without undue delay or expenses, using for that purpose the plant and materials above mentioned in so far as they are suitable and adaptable to such use. Upon the completion of the work the Bank shall certify the amount of the expenses properly incurred consequent on and incidental to the default of the Contractor as aforesaid and in completing the works by other persons. Should the amount so certified as the expenses properly incurred be less than the amount which would have been due to the Contractor upon the completion of the works by him, the difference shall be paid to the Contractor by the Employer and should the amount of the former exceed the latter, the difference shall be paid by the Contractor to the Employer. The Employer shall not be liable to make any further payment or compensation of the Contractor for or on account of the proper use of the plant for the completion of the works under the provisions thereinbefore mentioned other than such payment as included in the Contract. After the works shall have been so completed by persons other than Contractor, under provision herein before contained, the Bank shall give notice to the Contractor, to remove his plant and all surplus materials as may not have been used in the completion of the works, from the site. If such plant and materials are not removed within a period of 14(Fourteen) days, after the notice shall have been given, the Employer may remove and sell the same, holding the proceeds, less the cost of the removal and sale, to the credit of the contractor. The Employer shall not be so responsible for any loss sustained by the Contractor from the sale of the plant in the event of the Contractor not removing it after notice.

## **25. Termination of contract by the Employer**

- (a) If the Contractor being an individual or a firm commits any "act of insolvency" or shall be adjudged an Insolvent or being an Incorporated Company shall have an order for compulsory winding up made against it or pass an effective resolution for winding up voluntarily or subject to the supervision of the Court and the Official Assignee or the Liquidator in such acts of insolvency or winding up, as the case may be, shall be unable within seven days after notice to him requiring him to do so, to show to the reasonable satisfaction of the Bank that he is able to carry out and fulfil the contract and to give security thereof, if so required by the Bank.

Or if the Contractor (when an individual, firm or Incorporated Company) shall suffer execution or other process of Court attaching property to be issued against the Contractor.

Or shall suffer any payment under this contract to be attached by or on behalf of any of the creditors of the Contractors.

Or shall assign or sublet this contract without the consent in writing of the Employer first hand and obtained.

Or shall charge or encumber this contract or any payments due or which may become due to the Contractor hereunder.

Or if the Bank shall clarify in writing to the Employer that the Contractor :

- i. Has abandoned the contract, or
- ii. Has failed to commence the works, or has without any lawful excuse under these Conditions suspended the progress of the works for seven days after receiving from the Bank notice to proceed or
- iii. Has failed to proceed with the works with such due diligence and failed to make such due progress as would enable the works to be completed within the time agreed upon, or
- iv. Has failed to remove materials from the site or to pull down and replace work for seven days after receiving from the Bank written notice that the said materials or work were condemned and rejected by the Bank under these conditions, or
- v. Has neglected or failed persistently to observe and perform all or any of the acts, matters or things by this contract to be observed and performed by the Contractor for seven days after written notice shall have been given to the Contractor requiring the Contractor to observe or perform the same or
- vi. Has to the detriment of good workmanship or in defiance of Banks instructions to the contrary sublet any part of the contract

Then and in any of the said cases the Employer may, notwithstanding any previous waiver, after giving seven day's notice in writing to the Contractor, determine the contract, but without thereby affecting the powers of the Bank or the obligations and liabilities of the Contractor, the whole of which shall continue in force as fully as if the contract had not been so determined, and as if the works subsequently executed had been executed by or on behalf of the Contractor. And further, the Employer by his agents or servants may enter upon and take possession of the works and all plants tools, scaffoldings, sheds, machinery steam and other power equipment and materials lying upon the premises or the adjoining lands or roads, and use the same as his own property or may employ the same by means of his own servants and workmen in carrying on and completing the works or by employing any other Contractors or other person or persons to complete the works, and the Contractor shall not in any way interrupt or do any act, matter or things to prevent or hinder such other Contractor or other person or persons employed for completing and finishing or using the materials and plant for the works. When the works shall be completed or as soon thereafter as convenient the Bank shall give

a notice in writing to the Contractor to remove his surplus materials and plant, and should the Contractor fail to do so within a period of fourteen days after receipt thereof by him, the Employer may sell the same by public auction, and give credit to the Contract for the net amount realised. The Bank shall thereafter ascertain and certify in writing under this head what if any thing shall be due or payable to or by the Employer, for the value of the said plant and materials so taken possession of by the Employer and expense or loss which the Employer shall have been put to in procuring the works to be completed and the amount, if any, owing to the Contractor and the amount which shall be so certified shall thereupon be paid by the Employer to the Contractor or by the Contractor to the Employer, as the case may be, and the Certificate of the Bank shall be final and conclusive between the parties. On termination of contract the Contractor shall forthwith remove himself and his workmen from the work site. He will arrange to obtain photographs of the work completed till such date of termination which will be attested with date by the Bank.

b) Without prejudice to any of the rights or remedies under this contract, if the Contractor being an individual dies, the Employer shall have the option of termination of the contract without incurring any liability for such termination.

#### **26. Certificate of payments :**

a) The Contractor shall be paid by the Employer from time to time by instalments under Interim Certificates to be issued by the Bank to the Contractor on account of the works executed when in the opinion of the Bank work to the approximate value named in the Appendix as "value of Work for Interim Certificate" (or less at the reasonable discretion of the Bank's Engineer) has been executed in accordance with this contract, subject, however to a retention of the percentage of such value named in the Appendix hereto as "Retention percentage". The Bank may in his discretion include in the Interim Certificate such amount as he may consider proper on account of materials delivered upon the site by the Contractor for use in the works. And when the works have been virtually completed and the Bank shall have certified in writing that they have been completed, the Contractor shall be paid by the Employer in accordance with the Certificate to be issued by the Bank the sum of money named in the Appendix as "Instalment after virtual Completion" being a part of the said Security Deposit. The Contractor shall be entitled to the payment of the Final Balance in accordance with the final Certificate to be issued in writing by the Bank at the expiry of the period referred to as "Defects Liability Period" in the Appendix hereto from the date of Virtual completion and obtaining of clearance certificate from Labour Officer or as soon as after the expiration of such period as the works shall have been finally completed and all defects made good according to the true intent and meaning hereof whichever shall last happen, provided always that the issue by the Bank of any certificate during last happen, provided always that the issue by the Bank of any certificate during last the progress of the works or at or after their completion shall not relieve the Contractor from

his liability under Clause 2 and 20 nor relieve the Contractor of his liability in cases of fraud, dishonesty or fraudulent concealment relating to the works or materials or to any matter dealt with in the certificate, and in case of all defect and insufficiencies in the works or materials which a reasonable examination would not have disclosed. No certificate of the Bank shall of itself be conclusive evidence that any works or materials to which it relates are in accordance with the contract neither will the Contractor have a claim for any amounts which the Bank might have certified in any interim bill and paid by the Employer and which might subsequently be discovered as not payable and in this respect the Employer's decision shall be final and binding.

b) The Contractor has to submit alongwith his running account bills and final bill the following details :

- i. Abstract of bill all pages duly signed by Contractor & Site Engineer.
- ii. Copies of measurement sheets, all sheets duly signed by Contractor and Site Engineer.
- iii. Copies of test reports of materials and work.
- iv. Photographs of the work.
- v. Statement of consumption and receipt of material like steel, cement, paint, water proofing compound, anti-termite chemical etc.
- vi. Report on progress of works in comparison with CPM/PERT/Bar chart stating reasons for delay if any and measures proposed to cover the delay should accompany the bill.

c) 75% of the amount payable to the Contractor on the running account bills will be released by the employer as adhoc payment within 10 (ten) working days from the date of receipt of certificate issued by Bank Pending tests checking of work and measurements and checking of detailed arithmetical accuracy etc.

d) The Bank shall have power to withhold any Certificate if the works or any parts thereof are not being carried out to his satisfaction and the bill (running or final) not accompanied by the documents as stipulated in 31(c) above.

e) The Bank may by any Certificate make any correction in any previous certificate which shall have been issued by him.

f) No payment shall be made to the Contractor if the Contractor fails to insure the works and keep them insured till the issue of the Virtual Completion Certificate.

g) Payment upon the certified bills by banks representative/ engineer shall be made within the periods named in the Appendix as "Period for honouring Certificates".

**27. Matter to be finally determined by Bank :**

The decision opinion, direction, Certificate for payment with respect to all or any of the matters under clause 2, 4, 6, 7, 8, 12, 16 (b & c), 17, 19(a) (b), 20, 25(b), 27 (a, b, c, d, f) 28 hereof (which matters are herein referred to as excepted matters) shall be final and conclusive and binding on the parties hereto and shall be without appeal. Any other decision, opinion, direction. Certificate of valuation of the Bank or any refusal of the Bank to give any of the same shall be subject to the right of Arbitration and review under Clause 34 hereof in the same way in all respect (including the provisions as to opening the reference) as if it were a decision of the Bank.

**28. SETTLEMENT OF DISPUTE BY ARBITRATION :**

All disputes and differences of any kind whatsoever arising out of or in connection with this agreement or the carrying out of the works (whether during the progress of the works or within one year after their completion, or within one year after the determination or abandonment or breach of the contract) excepting however, on matters referred to in Clause 33 of Conditions of Contract hereof shall be referred by either party for arbitration after giving at least 30 (thirty) days notice in writing to the other(s) (hereinafter referred to as the 'Notice for Arbitration') clearly setting out the items of dispute for reference to a Sole Arbitration to be appointed as hereinafter provided.

For the purpose of appointing the Sole Arbitrator referred to above, the Employer will send to the Contractor within thirty days of the Notice for Arbitration, a panel of three names of persons who shall be presently unconnected with the organisation of the Employer and the Contractor.

The Contractor shall on receipt of the names as aforesaid, select any one of the persons so named to be appointed as a Sole Arbitrator and communicate his name to the Employer within thirty days of receipt of the names. The Employer shall thereupon without any delay appoint the said persons as the Sole Arbitrator. If the Contractor fails to communicate such selection as provided above within the period specified, the Employer shall make the selection and appoint a person from the said panel as the Sole Arbitrator.

If the Arbitrator so appointed is unable or unwilling to act or resign his appointment or vacates his office due to any reason whatsoever, another Sole Arbitrator shall be appointed as aforesaid.

The decision of the Employer/ bank's representative/engineer and with respect to the matters referred in clauses 33 of Conditions of Contract hereinabove, shall be final and outside the scope of arbitration. The Sole Arbitrator shall have power to open up, review and revise any certificate, opinion or decision, requisition or notice save in regard to matters enumerated in Clause 33 of Conditions of Contract hereof written and to determine all other matters in dispute which shall be submitted to arbitration and of which notice shall have been given as aforesaid. Subject to aforesaid, the Arbitration

shall be governed by the Indian Arbitration Act, 1940 or any other statutory modification thereof. The award of the Arbitrator shall be final and binding on the parties. It is hereby agreed that in all disputes referred to Arbitration, the Arbitrator shall give a separate Award in respect of each dispute or difference in accordance with the terms of the contract and give a reasoned Award.

The fees, if any, of the Arbitration shall, if required to be paid before the award is made and published, be paid half and half by each of the parties. The cost of the reference and of the award including the fees, if any, of the Arbitrator, shall be directed to be borne and paid by such party or parties to the dispute, in such manner or proportion as may be directed by the Arbitrator in the Award.

The Employer and the Contractor hereby also agree that the Arbitrator under this clause shall be a condition precedent to any right to action under the contract with regard to the matters hereby expressly agreed to be so referred to arbitration.

**B. WORK TO BE CONTINUED DURING THE PENDENCY OF THE ARBITRATION :** The Contractor shall continue with the construction works with due diligence and speed so as to complete the same within the period agreed upon, notwithstanding any dispute or difference or question is referred to arbitration. The work shall not be delayed on account of any such reference made to the Arbitrators.

**29. Right of Technical scrutiny of bill/inspection :**

- a) The Employer shall have a right to cause a technical examination of the works by any of the persons or organisation as appointed by the Employer and the final bill of the Contractor including all supporting vouchers abstracts, etc.

If as a result of this examination or otherwise under clause 35(a) above or 35(b) any sum is found to have been overpaid or over certified it shall be lawful for the Employer to recover the sum from any payment due to the Contractor for this work or any other work or works being carried out by Contractors elsewhere under NABARD.

- b) Inspection by the chief technical examiner (vigilance)

The proposed work covered under this tender, during its progress or after completion of work, can be inspected by the Chief Technical Examiner/Technical Examiner or by an officer of the vigilance cell of the Authority on behalf of the Employer/Engineer. The Contractor shall afford all reasonable facilities to the above vigilance staff as also provide them with ladders, tapes, plumb bob, level bottle, chisel and hammer, etc. as also necessary labour, skilled/unskilled, to complete their inspection/study/technical scrutiny to ascertain that execution of work has been done with materials and workmanship as stipulated in the contract, and no extra shall be admissible to the Contractor on this account.

**30. Employer entitled to recover compensations paid to workman :**

If, for any reason, the Employer is obliged, by virtue of the provisions of the Workmen's Compensation Act, 1923, or any statutory modification or re-enactment thereof to pay compensation to a workman employed by the Contractor in execution of the works, the Employer shall be entitled to recover from the Contractor the amount of compensation so paid and without prejudice to the rights of the Employer under the said Act. The Employer shall be at liberty to recover such amount or any part thereof by deducting it from the Security Deposit or from any sum due by the Employer to the Contractor under this contract or otherwise. The Employer shall not be bound to contest any claim made against it under the said Act, except on the written request of the Contractor and upon his giving to the Employer full security to the satisfaction of the Employer for all costs for which the Employer might become liable in consequence of contesting such claim.

**31. Abandonment of works :**

If at any time after the acceptance of the tender, the Employer shall for any reasons whatsoever not require the whole or any part of the work to be carried out, the Bank shall give notice in writing to the Contractor who shall have no claim to any payment of compensation or otherwise whatsoever on account of any profit or advantage which he might have derived from the execution of the whole works.

**32. Return of surplus materials :**

Notwithstanding anything to the contrary contained in any or all the clause of this contract, where any material for the execution of the contract is procured with assistance of the employer by purchases made under orders or permits or licenses issued by the Government, the Contractor shall hold the said materials economically and solely for the purpose of the contract and not dispose them without the prior written permission of the Employer and return it to the Employer, if required by the Employer, at the price to be determined by the Bank having due regard to the condition of the materials, the price to be determined not to exceed the purchase price thereof inclusive of sales tax, octroi and other such levies paid by Contractor in respect thereof. In the event of breach of the aforesaid condition, the Contractor shall in addition to being liable to action for contravention of the terms of licences or permit and or criminal breach of trust, be liable to Employer for all moneys, advantages or profits resulting or which in the usual course would have resulted to him by reason of such breach.

**33. PREPARATION OF BUILDING FOR OCCUPATION AND USE ON COMPLETION**

(a) On completion of the work, the Contractor shall inform the Bank in writing that he has finished the work and it is ready for the Architect/Clients' inspection. The Contractor shall clean all windows and doors including the cleaning and oiling if necessary of all hardware, inside and outside, all floors, staircases and every part of the building. He will leave the entire

building neat and clean and ready for occupation and to the satisfaction of the Bank/Employer.

b) **Guarantee** : The Contractor shall submit required guarantee for water proofing works, and anti-termite works as per Annexure-VI & VIII respectively after the work has been executed by the agencies so approved by the bank's representative/engineer/Bank's Engineer.

c) **As Built drawings** : The Contractor shall ensure four sets of "As Built" drawings are handed over to bank's representative/engineer for submitting the same to Architect/Municipal Corporation and record of Employer.

#### 34. **Marginal Notes** :

The marginal Notes and in the catch lines hereto, in the annexure, and the index hereto are meant only for convenience of reference and shall not in any way be taken into account in the interpretation of these presents and the annexures hereto. The Contractor will have to carry out and complete the said work in every respect in accordance with this contract.

35. **Address for service** : All letters and Notices under or pursuant to these presents shall be hand delivered against acknowledgement or sent by Registered Post with Acknowledgement Due or UPC at the respective address mentioned below. Any change in the address shall be duly intimated by the concerned party to all others.

- i. Address of Employer :
- ii. RO Address : 11, Vipin Khand, Gomti Nagar, Lucknow-226 010
- iii. HO Address : Bandra Kurla Complex, Bandra (East)-400 051.
- iv. Address of Bank :
- v. Address of Contractor :

(Alongwith postal address, Contractor must give the telephone, fax and e-mail number (if any) and must notify immediately in case of any change in the same)

## APPENDIX HEREINABOVE REFERRED TO

Ref. : To Clause in conditions herein before referred to elsewhere :

1. Period of Final Measurement : Three months from the date of Virtual completion
2. Date of commencement : 10<sup>th</sup> day of issue of work order or handing over of site whichever is earlier
3. Date of completion : 4 months from the date of start
4. Defects Liability Period : 12 months from the date of virtual completion certificate given by bank.
5. Rate of Liquidated Damages (0.25% of the cost put to tender) (subject to a maximum of 5% of the accepted tendered amount) : Rs. 4000.00 per week
6. Value of works for interim certificate : Rs. 4.0 lakh
7. Retention Percentage : 3%
8. Installment to be released after Virtual Completion : 50% of Security Deposit
9. Period of honouring Certificate of payment : 30 working days for Running A/c Bills and three months from date of Virtual completion certificates for final bill.
10. Security Deposit : Rs. 85000.00 (5% cost put to tender)

### **ADDITIONAL CONDITIONS**

1. The Building work will be carried out in the manner complying in all respects with the requirements of relevant bye laws of the local body under the jurisdiction of which the work is to be executed or as directed by the Engineer-in-charge and nothing extra will be paid on this accounts. The Contractor shall comply with proper and legal orders and directions of the local or public authority or municipality and abide by their rules and regulations and pay all fees and charges which he may be liable.

The Contractor shall take all precautions to avoid all accidents by exhibiting necessary caution boards day and night, speed limit boards, red flag, red lights and providing barriers. He shall be responsible for all damages and accidents caused due to negligence on his part. No hindrance shall be caused due to negligence on his part. No hindrance shall be caused to traffic during the execution of the work.

2. Cement bags shall be stored in separate godowns to be constructed by Contractor at his own cost as per sketch as page 398 of CPWD specifications 1977 Vol. I with weather proof roofs and walls. Each godown shall be provided with a single door with two locks.

3. The standard sectional weights referred to as standard tables in para 5.3.3 In specification for works, 1977 Vol. I to be considered for conversion of length of various sizes of M>S. bars and Tor Steel bars into weight are as under :

<b>Size (Diameter)</b>	<b>Weight</b>	<b>Size(Diameter)</b>	<b>Weight</b>
<b>Mm</b>	<b>Kg/m</b>	<b>Mm</b>	<b>Kg/m</b>
6	0.222	25	3.855
8	0.395	28	4.836
10	0.617	32	6.916
12	0.888	36	7.994
15	1.579	40	9.859
18	1.999	45	12.490
20	2.467	50	15.424
22	2.985		

Issue of steel of diameter above 10 mm will be regulated on sectional weight basis weight being calculated with the help of the above tables. However, for bars MS/l or steel upto and including 10 mm, the following procedure shall be adopted. The average sectional weight for each diameter shall be arrived at from samples from each lot of steel received at site. The actual weight of steel issued shall be modified to take into account the variations between the actual and the standard coefficients given above and the

Contractors' account will be debarred by the cost of this modified quantity only. The direction of the Banks Engineer shall be final for the procedure to be followed for determining the average sectional weight of each lot. Quantity of each diameter of steel received at site of work each day will constitute one single lot for this purpose.

**4. Testing of materials :**

a. Samples of various materials required for testing shall be provided free of charge by the Contractor. Testing charges if any, shall be borne by the Contractor. All other expenditure required to be incurred for taking the samples, conveyance. Parking etc. shall be borne by the Contractor himself.

b. In case there is any discrepancy in frequency of testing as given in list of mandatory test and that in individual sub-heads of work as per CPWD. Specifications 1977 (Vol. I), the higher of the two frequencies of testing shall be followed and nothing extra shall be payable to the Contractor on this account.

5. The contractor shall be responsible to arrange as his own cost all necessary tools and plants required for execution of the work.

6. The Contractor shall provide at his own cost suitable weighing and measuring arrangements at site for checking the weight/dimensions as may be necessary for execution of the work.

7. The foundation trenches shall be kept free from water while all the works below ground level are in progress.

8. Royalty at the prevalent rates whenever payable shall have to be paid by all Contractor on the boulders metal, shingle, sand and bajri etc. or any other materials collected by him for the work direct to the revenue authority of the District/State Government concerned. Where the District Revenue Authority levies Royalty on excavated material removed from the site, the same shall be paid by the Contractor and the cost should be included in his tendered rates.

## SPECIFICATIONS

### **1.00 General :**

1.1 The entire work shall be done as per CPWD specifications 1996 with upto date corrections slip. However, in the even of any discrepancy in the description of any item as given in the Schedule of quantities appended with the tender and the specifications relating to the relevant item as per CPWD specifications mentioned above the former shall prevail. If the specifications for any item are not available in the CPWD specifications cited above. Relevant I.S. specifications shall be followed in case ISI specifications are also not available the decision of the Banks' Engineer given in writing based on acceptable sound Engineering practice and local usage shall be final and binding on the Contractor.

The work shall be executed and measured as per metric dimensions given in the Schedule of quantities drawing etc. (FPS units wherever indicated are fair guidance only).

1.2 The following modifications, to be specifications and some additional specifications shall however apply :

i. All stone aggregate shall be of hard stone variety to be obtained from approved quarries at or any other source to be got approved by the Engineer-in-Charge.

ii. Sand to be used for cement concrete work, mortar for masonry and plaster work shall be of standard quality. Sand shall be obtained from the source to be got approved by the Engineer-in-charge and screen as required. The same shall consist of hard asillicicus material. It shall be clean stand, if the sand brought to site is dirty, it must be washed clean in water and should conform to clause 3.1.5.1 of CPWD specifications (Vol. I) 1977 for coarse sand except for grading purposes.

2.0 wherever any reference to any Indian standards specifications occurs in the documents relating to his contract the same shall be inclusive of all amendments issued their to or revisions thereof it any upto the date of receipt of tenders.

3.0 The rates for different items of works shall be for all heights and depth of the buildings except where otherwise specified in the items of work.

4.0 The work will be carried out in accordance with the architects drawings and structural Drgs. To be issued by the Bank's Engineer. The Structural and Architectural Drgs. Shall have to be property correlated before executing the work. In case of any difference noticed between Architectural and structural Drgs. Final decision in writing of the Banks Engineer shall be obtained by the Contractor. For items where so required samples shall be prepared before starting the particular items of work for prior approval of the Engineer-in-Charge and nothing extra shall be payable on this account.

5.0 Articles manufactured by reputed firms and approved by the Engineer-in-charge shall only be used. Only articles classified as "First quality" by the manufactures shall be used unless otherwise specified Preference shall be given to those articles, which bear ISI certification marks. In case articles bearing ISI certification marks are noOt available the quality of samples brought by the Contractor shall be judged by the standards laid down in the relevant CPWD specifications. For items not covered by CPWD specification. Relevant ISI standard shall apply.

6.0 The contractor shall give a performance test of installations as per specifications before the work is finally accepted and nothing extra whatsoever shall be payable to Contractor on this account.

7.0 The work shall be carried out in a manner complying in all respects with the requirements of relevant bye-laws of the Municipal Corporation/Development authority. Improvement trust under the jurisdiction of which the work is to be executed or as directed by the Engineer-in-charge and nothing extra shall be paid on this account.

8.0 Any cement slurry added over base surface (or) for continuation of concreting for better bond is added to have been in built in the item (unless otherwise/explecity stated) and nothing extra shall be payable (or) extra cement considered with consumption on the account.

9.0 The foundation trenches shall be kept free from water while all the works below ground level are in progress.

10.- The Fineness modulus of sand to be used in different works shall be as follows :

- |                |                                     |  |
|----------------|-------------------------------------|--|
| 1. Coarse sand | Fineness modulus between 2.5 to 3.5 | As specified in the item like Plain conc. RCC work flooring work etc.              |
| 2. Fine sand   | Fineness modulus between 1.2 to 1.6 | As specified in the item like finishing coat of cement, plaster skirting dado etc. |

11. **Brick works** : Bricks shall generally conform to specification and best quality available locally. Both the faces of wall of thickness more than 23 cm shall be kept in the proper plane. Wall of half brick thickness or less shall be measured separately and paid in sq.m. Half brick thickness shall be taken as 115 mm. Brick wall beyond half brick thickness shall be measured in multiples of half brick (i.e. 115 mm) shall be dedded to inclusive of mortar joints. When a fraction of half brick occurs due to architectural reasons or otherwise as per the requirements of the Department the same shall be measured as half brick work provided such fraction exceeds 2 cm. Fraction upto 2 cm thickness shall be made up in mortar and paid for as per specified thickness under brick work. Bricks shall be obtained from.

Or any other source to be got approved by Bank's Engineer and shall be of best quality well burnt ground moulded bricks available in the locality.

**12.00 RCC works :**

- 12.1 All RCC work shall be done strictly as per IS 456-2000 and IS 13920-1993.
- 12.2 High yield strength steel (deformed bars) having yield stress not less than 415 (FE 415) conforming to IS:1786-1985 shall be used as reimbursement unless specified otherwise.
- 12.3 Concrete specifications shall be as per IS:456-2000 and IS:13920-1993.
- 12.4 Concrete specifications shall be as follows unless specified otherwise.
  - a. Foundations – M20
  - b. Beams – M20
  - c. Column - M2
- 12.5 Clear minimum cover for reinforcement is as follows unless otherwise specified.
  - a. Column – 40mm
  - b. Beams – 25mm or the diameter of the bar whichever is greater.

**Annexure-1**

**ARTICLES OF AGREEMENT**

ARTICLES OF AGREEMENT made the \_\_\_\_\_ day of \_\_\_\_\_ between the National Bank for Agriculture and Rural Development having its Head Office at Mumbai (hereinafter called "the Employer) of the one part and

---

(hereinafter called "the Contractor") of the other part.

WHEREAS the Employer is desirous of Construction of construction of RCC retaining wall & boundary wall at plot no. 24/7, Indira Nagar, Lucknow and has caused drawings and specifications and additional specifications describing the works to be done.

AND WHEREAS the said Drawings numbered \_\_\_\_\_ to \_\_\_\_\_ inclusive, the CPWD Specifications with latest amendments, additional specifications, and the Schedule of Quantities have been signed by or on behalf of the parties hereto.

AND WHEREAS the Contractor has agreed to execute upon and subject to the Conditions set forth herein and the Conditions set forth in the Special Conditions and in the Schedule of Quantities and Conditions of Contract CPWD specification, additional conditions (all of which are collectively hereinafter referred to as "the said Conditions") the works shown upon the said Drawings and/or described in the said Specification, additional specifications and included in the Scheduled of Quantities at the Respective rate therein set forth amounting to the sum as therein arrived at or such other sum as shall become payable there under (hereinafter referred to as 'the said Contract Amount').

**NOW IT IS HEREBY AGREED AS FOLLOWS :**

1. In consideration of the said Contract Amount to be paid at the times and in the manner set forth in the said Conditions, the Contractors shall upon and subject the said Conditions execute and complete the work shown upon the said Drawings and described in the said Specifications, additional specification and the Scheduled of Quantities.
2. The Employer shall pay the Contractor the said Contract Amount or such other sum as shall become payable, at the time and in the manner specified in the said Conditions.
3. The said conditions, additional condition, specification additional specification and Appendix thereto shall be read and construed as forming part of this Agreement and the parties hereto shall respectively abide by, submit themselves to the said conditions and perform the Agreements on their part respectively in the said Conditions contained.

4. The term 'Structural Consultant' refers to M/s MINAS ENGINEERS & CONSULTANTS LUCKNOW or in the event of their ceasing to be the Consultants for this project, such other person or persons as may be appointed by the Employer.
5. The plans, agreement and documents mentioned herein shall form the basis of this contract.
6. This Contract is neither a fixed lump sum Contract nor a Piece Work Contract but is a Contract to carry out the work in respect of the entire construction of boundary wall & retaining wall to be paid for according to actual measured quantities at the rate contained in the Schedule of Rates and Probable quantities or as provided in the said Conditions.
7. The Contractor shall afford every reasonable facility for the carrying out of all works relating to civil works, installation of sanitary works and fittings, permanent water supply and other ancillary works in the manner laid down in the said conditions and shall make good any damages done etc. after the completion of such works.
8. Time shall be considered as the essence of this contract and the Contractor hereby agrees to commence the work soon after the site is handed over to him or from tenth day after the date of issue of formal work order as provided for in the said conditions whichever is later and to complete the entire work within 4 months (including monsoon months) subject nevertheless to the provisions for extension of time.
9. All payments by the Employer under this contract will be made only at Lucknow.
10. All disputes arising out of or in any way connected with this agreement shall be deemed to have arisen at Lucknow and only Courts in Lucknow shall have jurisdiction to determine the same.
11. That the several parts of this contract have been read by the Contractor and fully understood by the Contractor. The Contractor shall not be entitled for the payment for the quantities beyond the tendered quantities unless ordered for by specific written instructions from the Bank's Engineer.

<p>IN WITNESS WHEREOF THE Employer and the Contractor have set their respective hands to these presents and <u>two duplicates hereof</u> the day and year first herein above written</p>	<p>If the contractor is a partnership or an individual</p>
<p>IN WITNESS WHEREOF the Employer has set its hands to these presents through its duly authorised official and the Contractor has caused its common seal to be affixed hereunto and the said two duplicates/has caused these presents and the said two duplicates hereof to be executed on its behalf, the day and year first hereinabove written.</p>	

**Signature Clause**

<p>SIGNED AND DELIVERED by the National Bank for Agriculture and Rural Development by the hand of Shri _____ (name and designation _____) in the presence of</p> <p>1. _____ Address _____</p> <p>2. _____ Address _____</p> <p style="text-align: right;"><b>Witness</b></p> <p>Signed and Delivered by _____</p> <p>In the presence of (1) _____ Address _____</p> <p style="text-align: right;"><b>Witness</b></p>	<p>If the party is a partnership firm or an individual should be signed by all or on behalf of all the partners.</p>
<p>The COMMON SEAL OF _____</p> <p>Was hereunto affixed pursuant to the resolutions passed by its Board of Directors at the meeting held on _____ in the presence of</p> <p>1. _____</p> <p>2. _____</p>	
<p>Directors who have signed these presents in token thereof in the presence of</p> <p>1. _____</p> <p>2. _____</p>	<p>If the contractor signs under its common seal. The signature clause should tally with the sealing clause in the Articles of Association.</p>
<p>SIGNED AND DELIVERED BY the Contractor by the hand of Shri _____ duly constituted Attorney</p>	<p>If the Contractor is signing by hand of power of Attorneys whether a Company or Individual.</p>

**GUARANTEE IN LIEU OF EARNEST MONEY DEPOSIT**

THIS DEED OF GUARANTEE executed at ..... on this ..... day of ..... 2006 ..... by the ..... Bank, a banking company constituted under ..... having its Head Office at ..... (hereinafter referred to as the "the Surety", which expression shall unless repugnant to the context or meaning include its successors and assigns).

**IN FAVOUR OF**

**THE NATIONAL BANK OF AGRICULTURE AND RURAL DEVELOPMENT**, a corporation established under the National Bank for Agriculture and Rural Development Act, 1981, having its head office at C-24, G-Block, Bandra Kurla Complex, Bandra (East), Mumbai-400 051 and Regional Office at 11, Vipin Khand, Gomti Nagar, Lucknow (UP) (hereinafter referred to as "NABARD", which expression shall, unless repugnant to the context or meaning include its successors and assigns).

**WHEREAS**

- 1) NABARD desires to construct a boundary wall and RCC retaining wall at Plot No. 24/7, Indira Nagar, Lucknow.
- 2) It is one of the terms and conditions of the said request for quote/tender that the contractor will have to deposit a sum equivalent of Rs.....as and by way of Earnest Money Deposit (EMD) which is payable by the Contractor in cash or by Demand Draft (DD).
- 3) M/s .....having its registered office at ..... (hereinafter referred to as "our said constituents" which expression shall, unless

repugnant to the context or meaning, include its successors and assigns) intent to submit their quotations for the said work.

4) At the request of our said constituents, NABARD has agreed not to insist for Earnest Money Deposit payable by cash/DD and accept a guarantee from the Surety in lieu thereof as hereinafter contained.

NOW THEREFORE THIS DEED OF GUARANTEE WITNESSETH that in consideration of NABARD at our request, agreeing not to insist upon the Earnest Money Deposit in cash/DD and accepting this guarantee in lieu thereof, we the ..... bank, hereby unconditionally and irrevocably guarantee upto NABARD that our said constituents will perform all their duties and functions and discharge all their obligations under various terms and conditions of the said " Request for Tender" conditions to the full satisfaction of NABARD \* project management Consultant (PMC)/consultant/Architech failing which the surety shall on demand by NABARD, Lucknow the sum of Rs..... only.

2) the surety hereby further covenants that :

(i) the surety shall pay to NABARD the said sum not exceeding ..... on first demand of NABARD made in writing by NABARD without reference to our said constituents and notwithstanding any dispute or difference that may arise between NABARD and our said constituents.

(ii) That this guarantee shall be a continuing guarantee and shall not be revoked by the surety without prior consent in writing of NABARD.

(iii) The decision of NABARD on the breach of any terms and conditions of the said request for tender by our said constituents or their failure to perform obligations of discharge the duties under the said request for tender shall be final and binding on the surety and shall not be disputed by the surety either inside or outside forum such as court, tribunal, arbitration or other authority.

(iv) That the notice of demand in writing issued by NABARD shall be conclusive proof as regards the amount due and payable to NABARD under this guarantee and it shall not be disputed by the surety either inside or outside forum such as court, tribunal, arbitration or other authority.

(v) That any neglect or forbearance on the part of NABARD in enforcing any of the terms and conditions of the said request for tender or showing of any indulgence or negotiate further by NABARD with or said constituents or any variation in regard to the conditions contained in the said tender and thereby modify these conditions and add thereto any further conditions as may be mutually agreed upon between NABARD and our said constituents or any other act or deed on the part of NABARD which, but for his clause may have the effect of discharging the surety under the law relating to guarantee shall not discharge the surety from its obligations herein and the surety shall be discharged only by compliance by our said constituents of all their obligations, duties under the said request for quote/tender.

(vi) That this guarantee shall not be affected by any infirmity or absence or irregularity in the exercise of the powers by or on behalf of our aid constituents or winding up or merger or amalgamation of our aid constituents or by charge in the constitution or in the name of our said constituents.

(vii) That it shall not be necessary for NABARD to exhaust its remedies against our said constituents before invoking the guarantee and the guarantee herein contained shall be enforceable against the surety notwithstanding any other security which NABARD may have obtained or may obtain from our said constituents, any, at the time when this guarantee is invoked be outstanding and unrealised.

(viii) That the surety hereby agrees that this guarantee commences from the date hereof and shall remain in force till our constituents, if the tender is accepted by you, furnishes the security as required under the said specifications and executes a formal agreement therein provided and be in force for up to six months from the date of bank

guarantee and the surety hereby agrees to new this guarantee at the request of NABARD in the event of the said work given to our said constituents under the said request for tender is not completed.

ix) Any claim arising under this agreement shall be preferred by NABARD within a period of six months from the aforesaid date of the expiry of this guarantee and unless the claim is so preferred against the surety, the surety shall stand discharges of all its liabilities hereinunder.

IN WITNESS WHEREOF the within named surety has caused these presents to be executed on its behalf by the hand of its duly authorised official on the date and at the place first hereinabove written.

Signed, sealed and delivered for and on behalf of

The surety herein by the hand of

Shri ..... Its duly

authorised official

**Schedule of quantity for RCC Retaining wall and Brick masonry Bounadry wall at Plot no. 24/7 Indira Nagar Lucknow**

S.No	Item	Qty	Unit	Rate	Amount in Rs.
1	Clearing jungle including uprooting of rank vegetation, grass, brush wood, trees and saplings of girth upto 30 cm measured at a height of 1m above ground level and removal of rubbish safely outside the periphery of the area cleared	8000.00		sq m	
2	Earth work in excavation by mechanical means ( hydraulic excavator )/ manual means in foundation trenches or drains including dressing of sides and ramming of bottoms, lift upto 3.5m including getting out the excavated soil and disposal of surplus excavated soil as directed within a lead of 100 m in all kinds of soil.	341.00		cu m	
3	Filling with river bed material/ fly ash/ building rubbish( Brick bats, broken concrete only) / any type of soil for leveling of plot including compaction with roller and proper watering in layers of 20 cm ( Top layer to be filled with excated earth.)	900.00		Cum	
4	Providing and laying in position cement concrete of 1:4:8 (cement, coarse sand, stone 40mm size) grade excluding the cost of centring and shuttering	40.00		Cum	
5	Providing and laying in position 1:2:4( 1 Cement: 2 coarse sand: 4 graded stone aggregate 20 mm nominal size ) grade of reinforced cement concrete up to plinth level including the cost of centering and shuttering scaffolding, propping strutting etc. and removal of form work but excluding cost of reinforcement .	80.00		Cum	
6	Brick work with FPS bricks of clas designation 75 in foundation and plinth in 1:4 (cement, coarse sand).	92.00	Cum		
7	Providing and laying damp proof course 40mm thick with cement concrete 1:2:4 (cement, corase sand, graded stone 12.5mm size). along with providing and mixing water proofing material Impermo or equivalent in cement concrete work @ 1 Kg per 50 Kg of	65.00	sq m		

8	Brick work with FPS bricks of class designation 75 in superstructure above plinth level upto floor five level in cement mortar 1:4 (cement, coarse sand) with adequate provision of airholes, construction joints/expansion joints and 350mmx350 mm brick columns spaced at 3.0 m centre to centre, as directed by	109.00	cum		
9	'Reinforcement for RCC work including straightening, cutting bending , placing in position and binding all complete( HYSD)	4510.00	kg		
10	12mm cement plaster in 1:4 ( 1cement, 4 coarse sand ) mix over the boundary wall on both side.	806.00	Sq. m		
11	Finishing walls with premium Acrylic smooth exterior paint with Silicone additives of required shade on new work( two or more coats applied @ 1.43 ltr/10 sq.m over and including base coat of water proofing cement plant applied @ 2.20 kg /10 sq. m).	967.00	Sq.m		
12	Providing brick & CC coping with plaster finish to boundary wall as per architectural drawing.	268.47	m		
13	Providing and fixing MS gate as per approved drawings in structural steel including painting and fixing in RCC Pillars as directed by Bank. (Cost of pillars to be paid seperately).	1000.00	kg		
14	Providing and laying 100 mm dia SW pipes including breaking of for draining out rain waterfrom the plot .	10.00	m		
15	Lump sum charges for carrying out layout of plot and boundary wall/retaining wall through qualified surveyor with required survey equipments as per the site plan approved by UPAVN in due consulataion with incharge offiecrs of UPAVN.		1 LS		
			<b>Total</b>		

**Signature and seal of the tenderer/contractor**

**Note: Rate and amount shall be filled both in words and figures.**

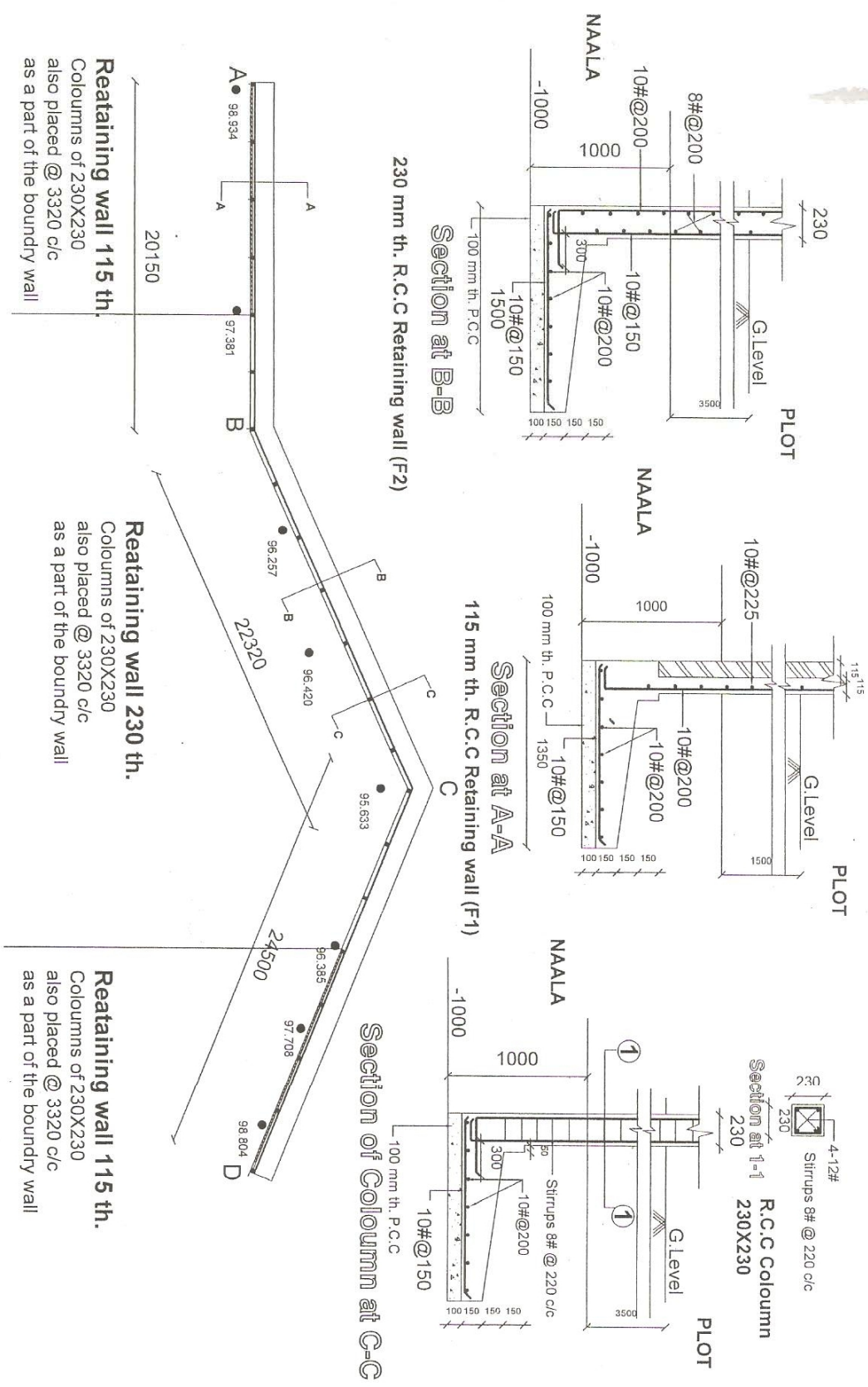

**Retaining wall 115 th.**  
 Columns of 230X230  
 also placed @ 3320 c/c  
 as a part of the boundary wall

**Retaining wall 230 th.**  
 Columns of 230X230  
 also placed @ 3320 c/c  
 as a part of the boundary wall

**Retaining wall 115 th.**  
 Columns of 230X230  
 also placed @ 3320 c/c  
 as a part of the boundary wall

**NOTES**

- 1-All dimensions are in mm unless specified other-wise.
- 2-All RCC construction work shall be done strictly as per IS 456-2000 & IS 13920-1993.
- 3-High yield strength steel (deformed-bars) having yield stress not less than 415 N/mm<sup>2</sup> (FE 415) conforming to IS 1786-1985 shall be used as reinforcement unless specified otherwise.
- 4-Concrete specifications shall be as per IS 456-2000 & IS 13920-1993.
- 5-Concrete mix shall be as follows unless specified otherwise :-  
 (A) Foundation - M20  
 (B) Beams - M20  
 (C) Columns - M20
- 6-Clear minimum cover for main reinforcement is as follows : unless specified otherwise :-  
 (A) Beam - 25mm or the diameter of the bar whichever is greater;  
 (B) Column - 40mm
- 7- Bending and fixing of bars for reinforcement shall be as per
- 8- Foundation has been designed for a soil bearing capacity of 10.00 T/M<sup>2</sup> below the filledup soil.
- 9- This structural drawing should be compared with the detailed relevant architectural drawing before execution.

**PROJECT**  
 PROPOSED OFFICERS COLONY  
 OF NABARD AT RING ROAD,INDIRA  
 NAGAR,LUCKNOW

**DRG. TITLE**  
 DETAILS OF RETAINING WALL  
 AT BACK SIDE BOUNDARY WALL

**NOTE:-** ALL THE DIMENSIONS ARE IN MM.  
 ONLY WRITTEN DIMENSIONS ARE TO  
 BE FOLLOWED

SCALE :- N.T.S

DATE :- MARCH, 2008

NABARD  
 PLOT NO. 24/7, INDIRA  
 NAGAR, LUCKNOW

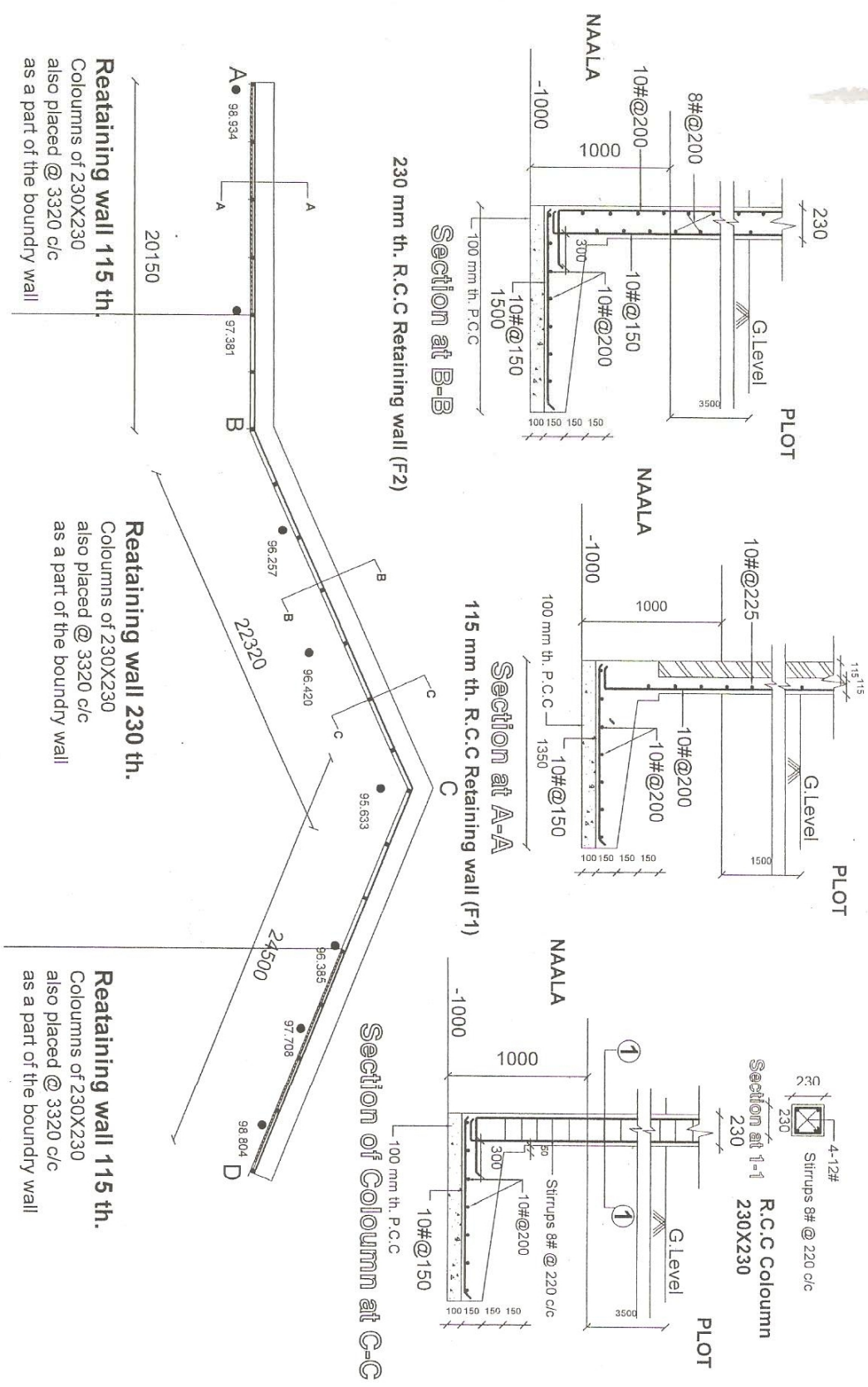

**Retaining wall 115 th.**  
Columns of 230X230  
also placed @ 3320 c/c  
as a part of the boundary wall

**Retaining wall 230 th.**  
Columns of 230X230  
also placed @ 3320 c/c  
as a part of the boundary wall

**Retaining wall 115 th.**  
Columns of 230X230  
also placed @ 3320 c/c  
as a part of the boundary wall

**NOTES**

- 1-All dimensions are in mm unless specified other-wise.
- 2-All RCC construction work shall be done strictly as per IS 456-2000 & IS 13920-1993.
- 3-High yield strength steel (deformed-bars) having yield stress not less than 415 N/mm<sup>2</sup> (FE 415) conforming to IS 1786-1985 shall be used as reinforcement unless specified otherwise.
- 4-Concrete specifications shall be as per IS 456-2000 & IS 13920-1993.
- 5-Concrete mix shall be as follows unless specified otherwise :-  
(A) Foundation - M20  
(B) Beams - M20  
(C) Columns - M20
- 6-Clear minimum cover for main reinforcement is as follows : unless specified otherwise :-  
(A) Beam - 25mm or the diameter of the bar whichever is greater;  
(B) Column - 40mm
- 7- Bending and fixing of bars for reinforcement shall be as per
- 8- Foundation has been designed for a soil bearing capacity of 10.00 T/M<sup>2</sup> below the filledup soil.
- 9- This structural drawing should be compared with the detailed relevant architectural drawing before execution.

**PROJECT**  
PROPOSED OFFICERS COLONY  
OF NABARD AT RING ROAD,INDIRA  
NAGAR,LUCKNOW

**DRG. TITLE**  
DETAILS OF RETAINING WALL  
AT BACK SIDE BOUNDARY WALL

**NOTE:-** ALL THE DIMENSIONS ARE IN MM.  
ONLY WRITTEN DIMENSIONS ARE TO  
BE FOLLOWED

SCALE :- N.T.S

DATE :- MARCH, 2008

NABARD  
PLOT NO. 24/7, INDIRA  
NAGAR, LUCKNOW

# DETAILS OF WALL

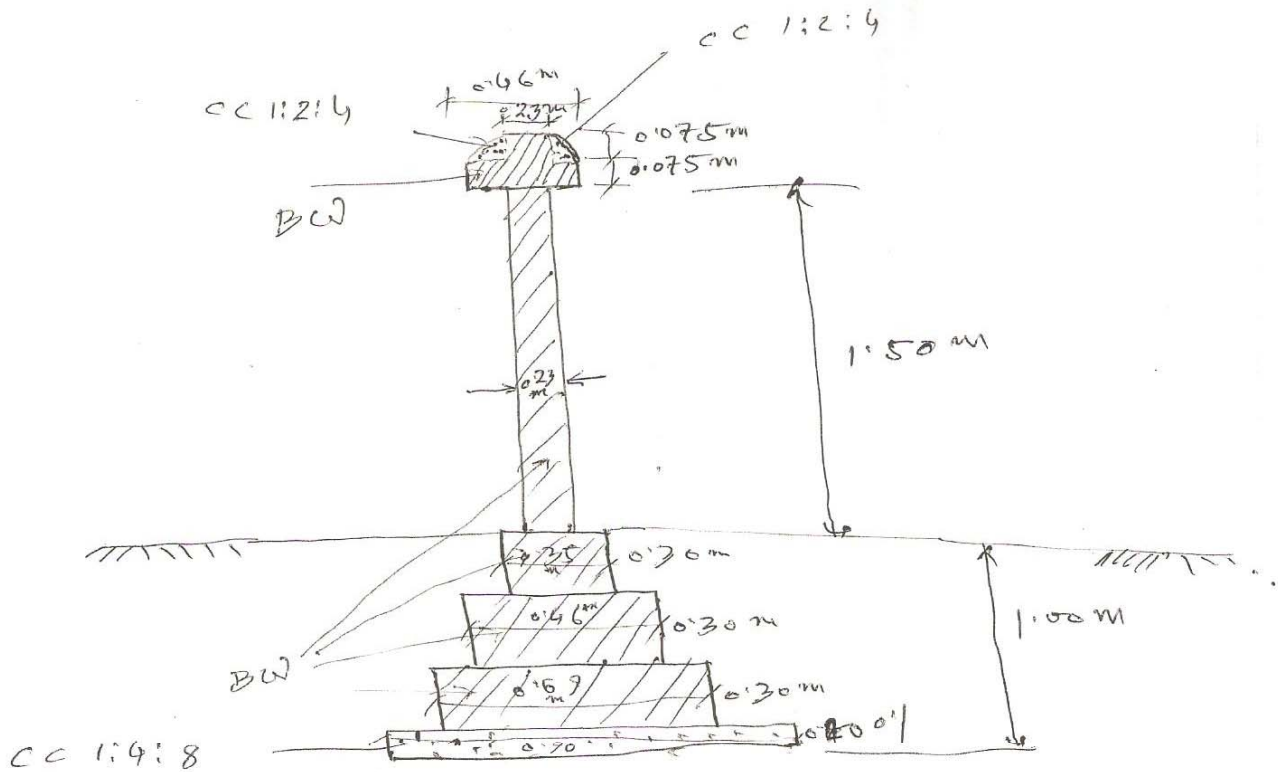

INDICATIVE DRAWING

SECTION: 230mm thick brick masonry boundary wall

Provision of 350x350mm brick columns, air holes and construction  
 / expansion joints to be made as per directions of the bank.

SITE - PLOT No. 24/7 INDIRA  
 NAGAR, LUCKNOW.

NABARD  
 U.P.-R.O. LUCKNOW.